

STYLISTIC Q550

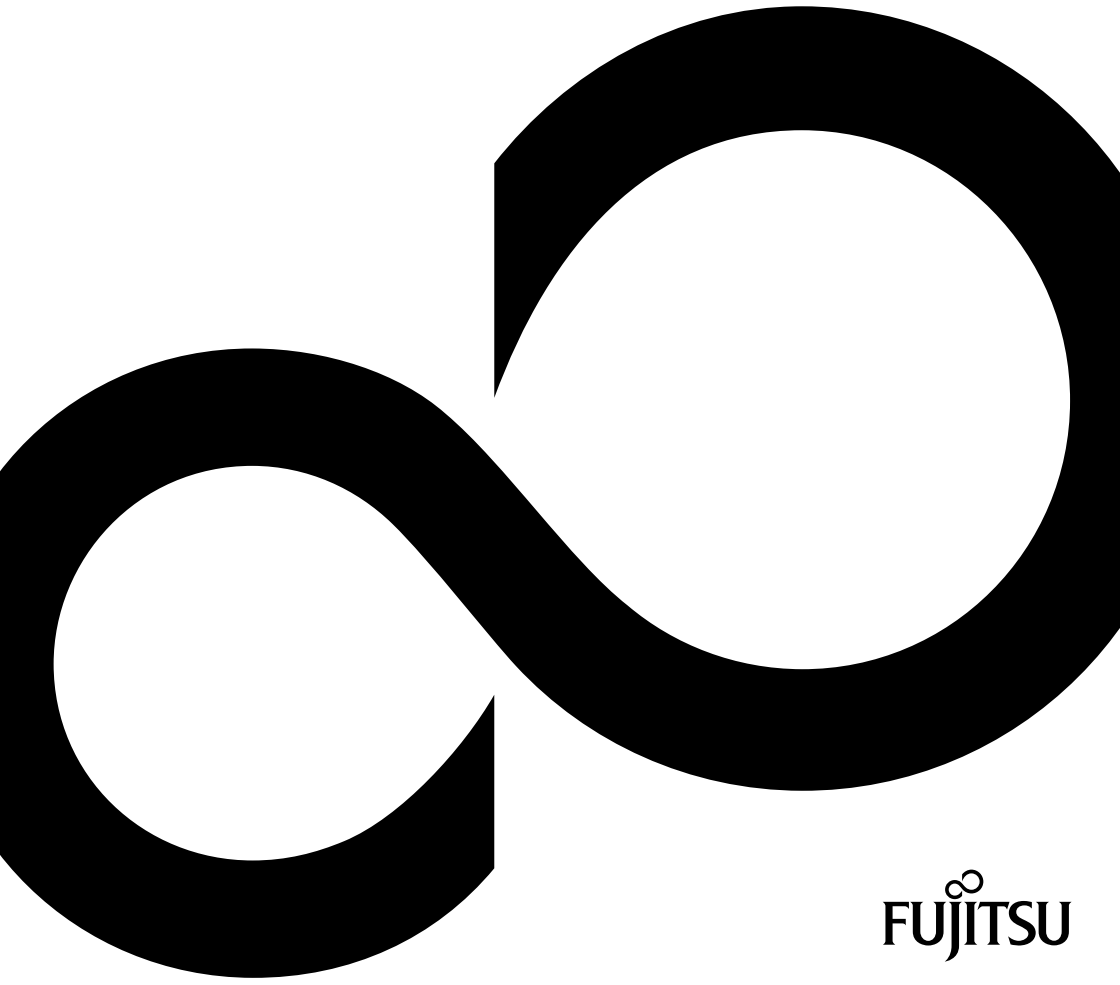

Congratulations, you have decided to buy an innovative Fujitsu product.

The latest information about our products, useful tips, updates etc. is available from our website: ["http://ts.fujitsu.com"](http://ts.fujitsu.com)

For automatic driver updates, go to: ["http://support.ts.fujitsu.com/com/support/index.html"](http://support.ts.fujitsu.com/com/support/index.html)

Should you have any technical questions, please contact:

- our Hotline/Service Desk (see Service Desk list or visit: ["http://ts.fujitsu.com/support/servicedesk.html"](http://ts.fujitsu.com/support/servicedesk.html))
- Your sales partner
- Your sales office

We hope you really enjoy using your new Fujitsu system.

**Copyright**

Fujitsu Technology Solutions 2011 04/11

Published by

Fujitsu Technology Solutions
Mies-van-der-Rohe-Straße 8 (Mies-van-der-Rohe Street No. 8)
80807 Munich, Germany

Contact

<http://ts.fujitsu.com/support>

All rights reserved, including intellectual property rights. Subject to technical alterations. Delivery subject to availability. No warranty is offered or liability accepted in regard of the completeness, correctness, or current applicability of any data or illustrations. Brand names may be protected trademarks of the respective manufacturer and/or protected by copyright. Use of these by third parties for their own purposes may constitute an infringement of the holders' rights. Further information can be found at "http://ts.fujitsu.com/terms_of_use.html"

Order No. Fujitsu Technology Solutions GmbH: A26391-K330-Z320-1-7619, edition 1

STYLISTIC Q550

Operating manual

Innovative technology	7
Ports and controls	9
Important notes	11
First-time setup of your device	17
Working with the Tablet PC	20
Security functions	53
Connecting external devices	60
Settings in BIOS Setup Utility	64
Troubleshooting and tips	67
Technical data	75
Manufacturer's notes	77
Index	84

Microsoft, MS and Windows are registered trademarks of the Microsoft Corporation.

Adobe Reader is a trademark of Adobe Systems Incorporated.

MultiMediaCard is a registered trademark of Infineon Technologies AG

Sony and Memory Stick are registered trademarks of Sony Electronics, Inc.

All other trademarks referenced are trademarks or registered trademarks of their respective owners, whose protected rights are acknowledged.

Copyright © Fujitsu Technology Solutions GmbH 2011

All rights reserved, including rights of translation, reproduction by printing, copying or similar methods, in part or in whole.

In the event of violations, perpetrators will be liable to prosecution for damages.

All rights reserved, including rights created by patent grant or registration of a utility model or design.

Subject to availability and technical modifications.

Contents

Innovative technology	7
Further information	7
Notational conventions	8
Ports and controls	9
Important notes	11
Safety notes	11
Additional safety notes for devices with radio components	11
Protecting the display screen	12
Energy saving	15
Energy saving under Windows	15
Travelling with your Tablet PC	15
Before you travel	15
Transporting the Tablet PC	16
Cleaning the Tablet PC	16
First-time setup of your device	17
Unpacking and checking the device	17
Selecting a location	18
Mains adapter connecting	18
Switching on the device for the first time	19
Working with the Tablet PC	20
Status indicators	20
Switching on the Tablet PC	21
Programming the ON/OFF switch	21
Switching off the Tablet PC	21
Handwriting recognition under Windows 7	22
Touchscreen	22
Select display orientation (portrait or landscape orientation)	23
Using fingers	23
Calibrate the Dual Digitizer for finger-based operation of the device.	23
Actions with one finger	24
Actions with two fingers	24
Actions with three fingers	26
Actions with four fingers	29
Using the stylus pen	33
Setting the pen	34
Calibrating the pen	35
Changing the pen tip	35
Removing the pen battery	36
Installing a pen battery	36
Installing a pen cord	36
Tablet buttons	37
Programming the tablet buttons	38
Webcam	39
Rechargeable battery	39
Charging, caring for and maintaining the battery	40
Removing and installing the battery	40
Using the power-management features	43
Memory cards	44

Supported format	44
Inserting the memory card	44
Removing the memory card	45
SIM card	45
Inserting the SIM card	46
Removing a SIM card	46
Wireless LAN / Bluetooth / UMTS	46
Switching the wireless components on and off	47
Setting up WLAN access	48
Access via UMTS	48
GPS	48
Your Cradle (optional)	48
Cradle components	49
Setting up the Cradle	50
Connecting the Tablet PC to the Cradle	50
Disconnecting the Tablet PC from the Cradle	52
Security functions	53
Configuring the fingerprint sensor	53
Configuring password protection in BIOS Setup Utility	54
Protecting BIOS Setup Utility (supervisor and user password)	54
Password protection for booting of the operating system	55
Password protection for the hard disk	56
SmartCard reader	58
Inserting the SmartCard	58
Trusted Platform Module (TPM) (device-dependent)	59
Enabling TPM	59
Disabling TPM	59
Connecting external devices	60
HDMI port	61
Connecting USB devices	62
How to remove USB devices correctly	62
Headphone port	63
Settings in BIOS Setup Utility	64
Starting the BIOS Setup Utility	64
Operating BIOS Setup Utility	65
Exiting BIOS Setup Utility	66
Exit Saving Changes - save changes and exit BIOS Setup Utility	66
Exit Discarding Changes – Discard changes and exit BIOS Setup Utility	66
Load Setup Defaults – Copy Standard Entries	66
Discard Changes – Discard changes without exiting the BIOS Setup Utility	66
Save Changes - save changes without exiting the BIOS Setup Utility	66
Save Changes and Power Off	66
Troubleshooting and tips	67
Help if problems occur	67
The Tablet PC's date or time is incorrect	68
Battery indicator does not illuminate	68
The Tablet PC's touchscreen remains dark	68
The display on the Tablet PC's touchscreen is difficult to read.	68
The external monitor remains blank	69
The external monitor is blank or the image is unstable	69

The cursor does not correctly follow the pen movements	70
Pen input not working	70
The Tablet PC does not start after switch on	70
The Tablet PC stops working	71
The printer does not print	71
The radio connection to a network does not work	71
The battery discharges too quickly	72
SmartCard reader is not recognised.	72
SmartCard PIN forgotten	72
SmartCard lost	72
User and/or supervisor SmartCard lost	73
Acoustic warnings	73
Error messages on the screen	73
Technical data	75
Tablet PC	75
Rechargeable battery	76
Mains adapter (40 W)	76
Cradle (optional)	76
Manufacturer's notes	77
Disposal and recycling	77
Declarations of Conformity	77
Tested safety (TS, depending on the device)	77
CE marking	78
Regulatory notices	78
Regulatory information for Tablet PCs without radio device	78
DOC (Industry CANADA) notices	80
FCC Regulatory information for Tablet PCs with radio device	81
Index	84

Innovative technology

... and ergonomic design make your device a reliable and convenient companion.

The device boots very quickly, is ready for immediate use and offers a particularly long operating time because of its high capacity battery.

The user-friendly "BIOS Setup Utility" offers powerful password protection functions which can be used to control your Tablet PC's hardware and protect your system better against unauthorised use.



Information on the connections and controls for your Tablet PC can be found in chapter ["Ports and controls", Page 9](#).

Further information









The Windows drivers for your device can be found on our Internet site. The factory installation of your device does not support any other operating system. Fujitsu Technology Solutions accepts no liability whatsoever if any other operating system is used.

Software oriented components of these instructions refer to Microsoft products, if they come within the scope of the delivery.

If you install other software products, pay attention to the operating instructions of the manufacturer.

Notational conventions

	Pay particular attention to text marked with this symbol. Failure to observe these warnings could pose a risk to health, damage the device or lead to loss of data. The warranty will be invalidated if the device becomes defective through failure to observe these warnings.
	Indicates important information for the proper use of the device.
	Indicates an activity that must be performed
	Indicates a result
This font	indicates data entered using the keyboard in a program dialogue or at the command line, e.g. your password (Name123) or a command used to start a program (start.exe)
This font	indicates information that is displayed on the screen by a program, e.g.: Installation is complete.
<i>This font</i>	Indicates <ul style="list-style-type: none"> • terms and texts used in a software interface, e.g.: Click on <i>Save</i> • names of programs or files, e.g. <i>Windows</i> or <i>setup.exe</i>.
"This font"	Indicates <ul style="list-style-type: none"> • cross-references to another section, e.g. "Safety information" • cross-references to an external source, e.g. a web address: For more information, go to "http://ts.fujitsu.com" • Names of CDs, DVDs and titles or designations for other materials, e.g.: "CD/DVD Drivers & Utilities" or "Safety/Regulations" manual
	indicates a key on the keyboard, e.g: 
This font	indicates terms and texts that are emphasised or highlighted, e.g.: Do not switch off the device

Ports and controls

This chapter presents the individual hardware components of your device. It gives you an overview of the device's indicators and connections. Please familiarise yourself with these components before you start to work with the device.

Front

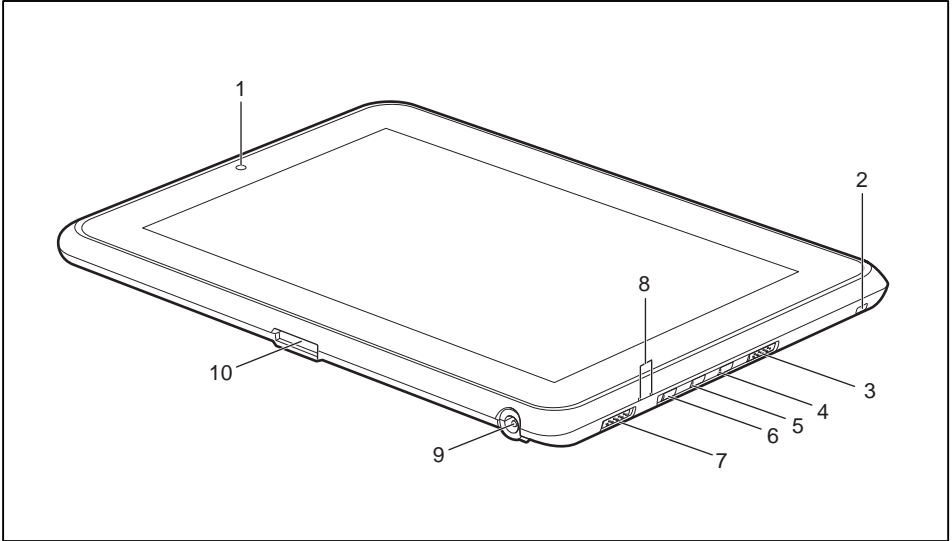

- | | |
|---|--------------------------------|
| 1 = WebCam | 6 = Tablet button "Keyboard" |
| 2 = Eyelet for pen cord | 7 = ON/OFF switch |
| 3 = ON/OFF switch for wireless components | 8 = Status indicators |
| 4 = Tablet button "Alt"
(function Ctrl + Alt + Del) function | 9 = DC input connector (DC IN) |
| 5 = Tablet button "Change the screen orientation" | 10 = Port for Cradle |

Rear

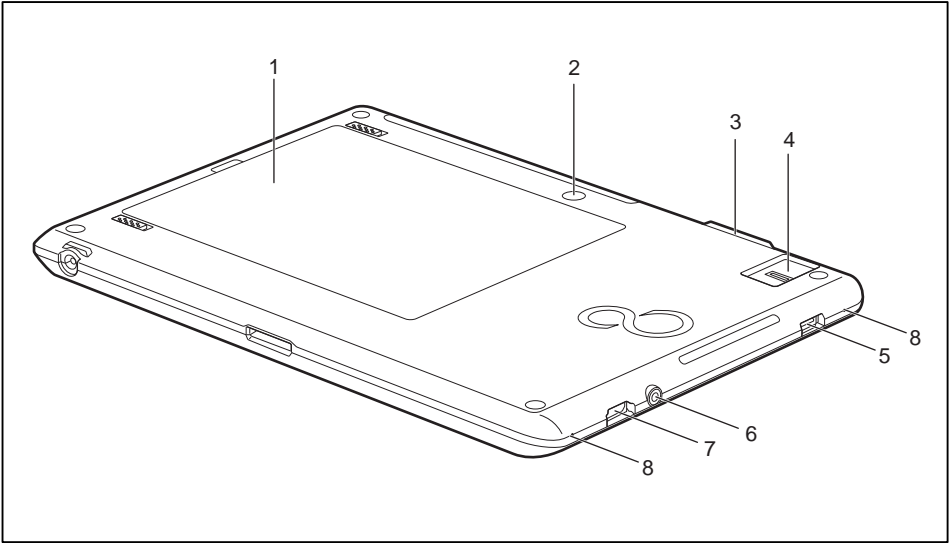

- 1 = Battery compartment
- 2 = WebCam
- 3 = Memory card slot
- 4 = Fingerprint sensor

- 5 = USB port
- 6 = Headphone port
- 7 = HDMI port
- 8 = Microphones

Important notes



This chapter contains essential safety information which must be followed when working with your Tablet PC. The other notes provide useful information on your Tablet PC.

Safety notes



Please follow the safety notes provided in the "Safety/Regulations" manual as well as the safety notes given below.

Please pay special attention to the sections in the manual marked with the symbol on the left.

When connecting and disconnecting cables, observe the relevant notes in this operating manual.

Read the information on the ambient conditions in the "[Technical data](#)", [Page 75](#) chapter and the "[First-time setup of your device](#)", [Page 17](#) chapter before preparing your Tablet PC for use and switching it on for the first time.

When cleaning the device, please observe the relevant notes in the section "[Cleaning the Tablet PC](#)", [Page 16](#).

Pay attention to the additional safety notes for devices with radio components provided in the "Safety/Regulations" manual.

This Tablet PC complies with the relevant safety regulations for data processing equipment. If you have questions as to whether you can set up the Tablet PC in the intended environment, please contact your sales point or our hotline/help desk.

Additional safety notes for devices with radio components

If a radio component (Wireless LAN/ Bluetooth) is integrated in your Tablet PC, you must be sure to observe the following safety precautions when using your Tablet PC:

- Switch off the radio components when you are in an aircraft or driving in a car.
- Switch off the radio components when you are in a hospital, an operating room or near a medical electronics system. The transmitted radio waves can impair the operation of medical devices.
- Switch off the radio components when you let the device get near flammable gases or into hazardous environments (e.g. petrol station, paintshops), as the transmitted radio waves can cause an explosion or a fire.



For information on how to switch radio components on and off, see chapter "[Switching the wireless components on and off](#)", [Page 47](#).

Protecting the display screen



The device is not waterproof. Do not pour liquids on the system or wash it with a heavily soaked cloth. Do not place items on the top of the display, or damage may occur.

During normal use of the device, small particles from the environment can become embedded in the pen tip and scratch the screen. To prevent scratching the screen, ensure that a screen protector is installed before using your device. The warranty does not cover a scratched screen.

Your device is designed for a long period of use. Using a screen protector will help ensure that the screen remains as clear as possible. When installed, the screen protector becomes a durable, replaceable writing surface that protects the display screen from abrasion.

The screen protector is held onto the display screen surface by a thin strip of adhesive around the edges. There is an angled corner in one corner of the screen protector. It allows you to slide your fingernail under the screen protector for easy removal.



Please contact your dealer for additional screen protectors.

Proceed as follows to attach a screen protector:

- ▶ If a screen protector is already installed on the display screen, remove it before installing the new screen protector.

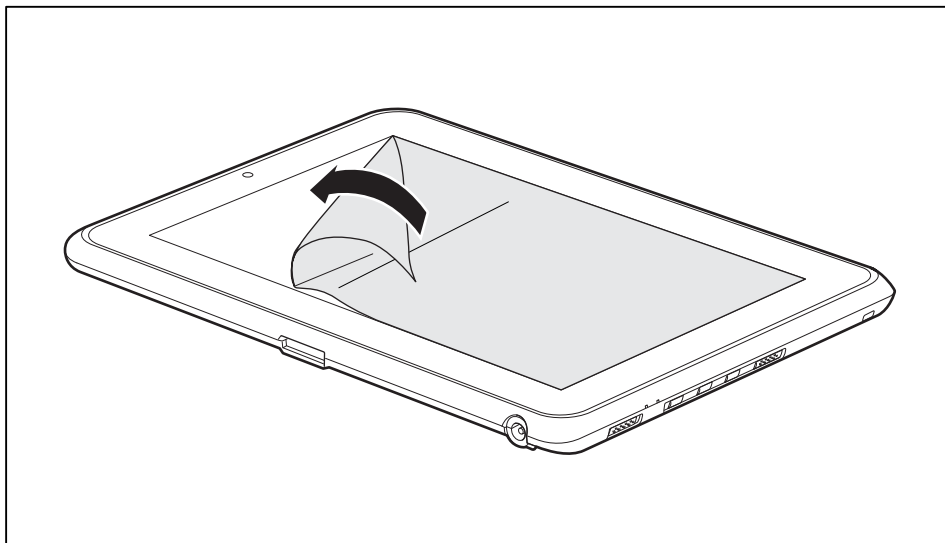

- ▶ Remove the protective coating from the adhesive side of the screen protector.

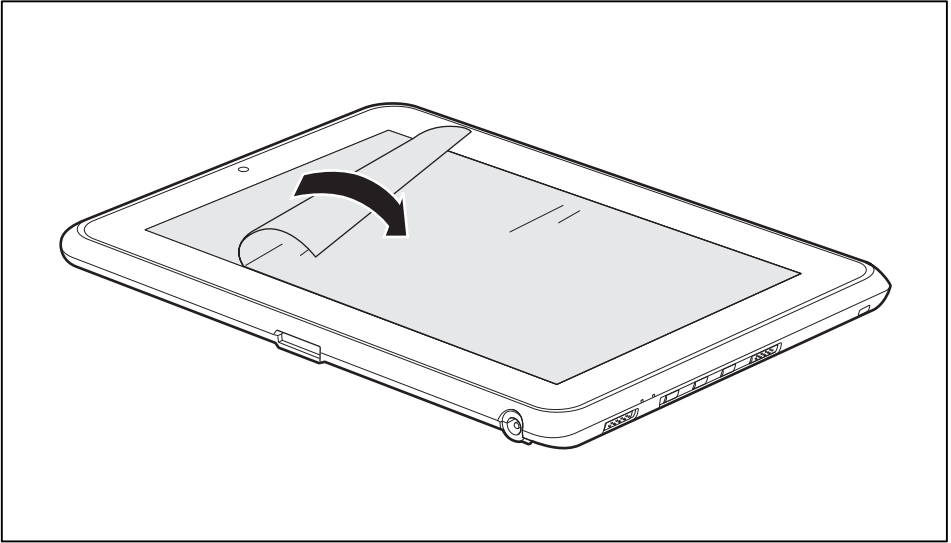

- ▶ Align the screen protector on the edges of the screen as illustrated and lay it on the screen with the adhesive side downward.
- ▶ Make stroking movements towards the outside edges in order to remove any air bubbles.
- ▶ Press the edges firmly.



To ensure a good seal between the screen protector and the display, do not lift the screen protector from the display once it has been applied.

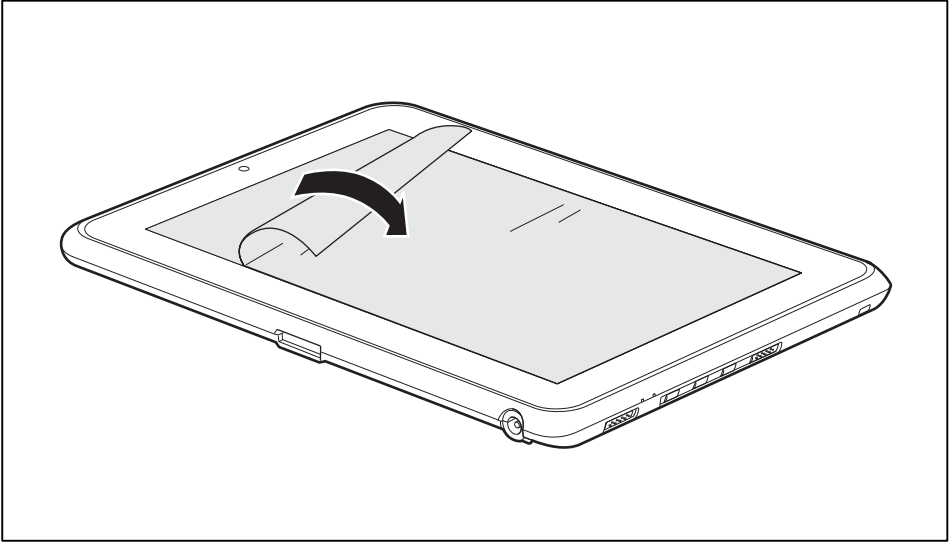

- ▶ Carefully lift the plastic protective coating at the angled corner and pull it from the screen.
- ↳ You can now touch the screen with the pen.
- ▶ To remove all adhesive residue and prevent the tip of the pen from squeaking, wipe the screen protector with a soft, dry cloth.



The adhesive sets completely within 48 hours.

Energy saving

If you will not be using your Tablet PC, switch it off. Switch off any connected external devices when they are not in use. If you use the energy saving functions, the Tablet PC uses less power. You will then be able to work for longer before having to recharge the battery.



Energy efficiency is increased and the environmental impact is reduced. You save money while protecting the environment.

Energy saving under Windows

- ▶ Make use of the power management features (see ["Using the power-management features", Page 43](#)).

Travelling with your Tablet PC

Please observe the points listed below when travelling with your Tablet PC.

Before you travel

- ▶ Back up important data stored on your hard disk.
- ▶ Switch off the radio component for data security reasons. With data traffic via a wireless connection, it is also possible for unauthorised third parties to receive data.



Information on activating data encryption is provided in the documentation for your radio component.

- ▶ If you want to use your Tablet PC during a flight, first check with the flight attendants whether this is permissible.

When travelling in other countries

- ▶ If you are travelling abroad, check that the mains adapter can be operated with the local mains voltage. If this is not the case, obtain the appropriate mains adapter for your Tablet PC. Do not use any other voltage converter!
- ▶ Check whether the local mains voltage and the power cable are compatible. If this is not the case, buy a power cable that matches the local conditions.
- ▶ Enquire with the corresponding government office of the country you will be travelling in as to whether you may operate the radio component integrated in your Tablet PC there (also see ["CE marking", Page 78](#)).

Transporting the Tablet PC



Protect the Tablet PC from severe shocks and extreme temperatures (e.g., direct sunlight in a car).

- ▶ If your device has an optical drive, remove all data media (e.g. CD, DVD) from the drives.
- ▶ Switch off the Tablet PC.
- ▶ Unplug the mains adapter and all external devices from the power socket.
- ▶ Disconnect the mains adapter cable and the data cables for all external devices.
- ▶ To protect against damaging jolts and bumps, use a Tablet PC carrying case to transport your Tablet PC.

Cleaning the Tablet PC



Do not clean any interior parts yourself; leave this job to a service technician.

Only use cleaning products designed for computers. Normal household cleaners and polishes can damage the markings on the keyboard and the Tablet, the paintwork or the Tablet PC itself.

Please ensure that no liquid enters the Tablet PC.

The touchscreen is very sensitive to scratches! Only clean the display surface with a very soft, slightly damp cloth.

- ▶ Switch the Tablet PC off.
- ▶ In order to prevent accidentally switching the device on, remove the power cable from the mains adaptor and remove the battery (see "[Removing and installing the battery](#)", Page 40).
- ↳ The casing surfaces may be cleaned with a dry cloth. If particularly dirty, use a damp cloth that has been dipped in water mixed with mild domestic detergent and then carefully wrung out.

First-time setup of your device



Please read the chapter "[Important notes](#)", [Page 11](#).

If your device is equipped with a Windows operating system, the necessary hardware drivers and supplied software are already pre-installed.

Before you switch on the device for the first time, connect it to the mains voltage using the mains adapter, see "[Mains adapter connecting](#)", [Page 18](#). The mains adapter must be connected during the entire installation process.

A system test is performed when your device is first switched on. Various messages can appear. The display may remain dark for a short time or may flicker.

Please follow the instructions on the screen.

NEVER switch off your device during the first-time setup process.

On delivery, the battery can be found in the battery compartment or in the accessories kit. The battery must be charged if you want to operate your device using the battery.

When used on the move, the built-in battery provides the device with the necessary power. You can increase the operating time by using the available energy-saving functions.

For instructions on how to connect external devices (e.g. mouse, printer) to your device, please refer to the operating manual for your device.

Unpacking and checking the device



Should you discover any damage that occurred during transportation, notify your local sales outlet immediately!

- ▶ Unpack all the individual parts.
- ▶ Check your device for any visible damage which may have occurred during transportation.



You may need the packaging in the future, if you need to transport your device.

Selecting a location



Select a suitable location for the device before setting it up. Follow the instructions below when doing so:

- Never place the device or the mains adapter on a heat-sensitive surface. The surface could be damaged as a result.
- Never place the device on a soft surface (e.g. carpeting, upholstered furniture, bed). This can block the air vents and cause overheating and damage.
- The underside of the device heats up during normal operation. Prolonged contact with the skin may become unpleasant or even result in burns.
- Place the device on a stable, flat, non-slippery surface. Please note that the rubber feet of the device may mark certain types of delicate surfaces.
- Keep other objects at least 100 mm away from the device and its mains adapter to ensure adequate ventilation.
- Never cover the ventilation slots of the device.
- Do not expose the device to extreme environmental conditions. Protect the device from dust, humidity, and heat.

Mains adapter connecting



Observe the safety notes in the enclosed "Safety/Regulations" manual.

The supplied power cable conforms to the requirements of the country in which you purchased your device. Make sure that the power cable is approved for use in the country in which you intend to use it.

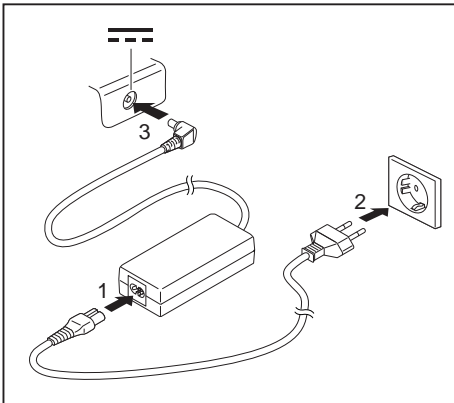

- ▶ Connect the power cable (1) to the mains adapter.
- ▶ Plug the mains cable (2) into a mains outlet.
- ▶ Connect the mains adapter cable (3) to the DC jack (DC IN) of the device.

Switching on the device for the first time



On devices with ON/OFF switch for wireless components: Slide the ON/OFF switch for wireless components to the ON position before switching on the device.

When you switch on the device for the first time, the supplied software is installed and configured. Because this procedure must not be interrupted, you should set aside enough time for it to be fully completed and connect the device to the mains using the mains adapter.

During the installation process, **DO NOT** restart the device unless you are requested to do so!

To make it easier to use your device for the first time, the operating system is pre-installed on the hard disk.

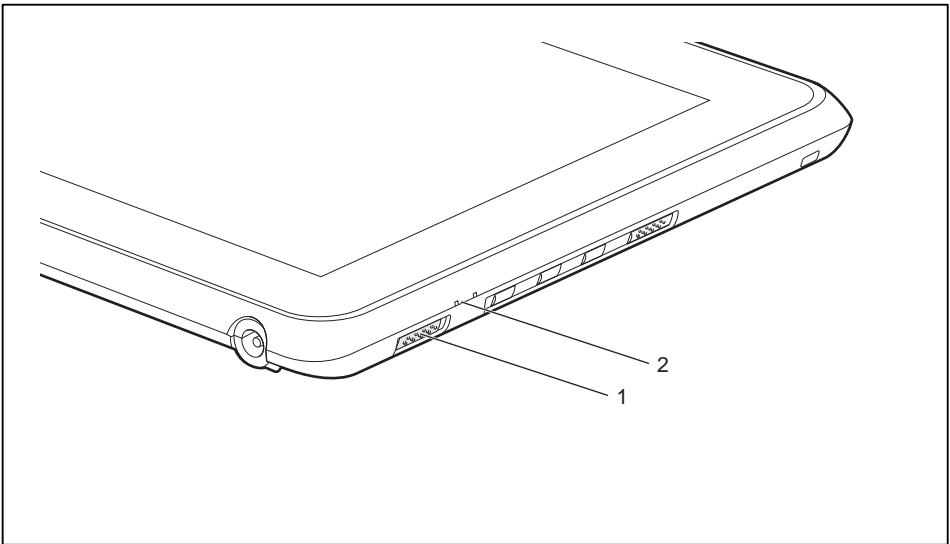

- ▶ Slide the ON/OFF switch (1) to the right to switch on the Tablet PC.
- ↳ The ON/OFF switch returns automatically to its original position.
The power-on indicator (2) lights up whenever the system is switched on.
- ▶ During installation, follow the instructions on screen.



If a Windows operating system is installed on your device, you will find more information on the system and drivers, help programmes, updates, manuals etc. on the device or on the Internet at ["http://ts.fujitsu.com/support"](http://ts.fujitsu.com/support).

Working with the Tablet PC

This chapter describes the basics for operating your Tablet PC. You can find instructions on how to connect external devices (e.g. mouse, printer) to the Tablet PC in the chapter ["Connecting external devices", Page 60](#).





Please refer to the notes in ["Important notes", Page 11](#).

Status indicators

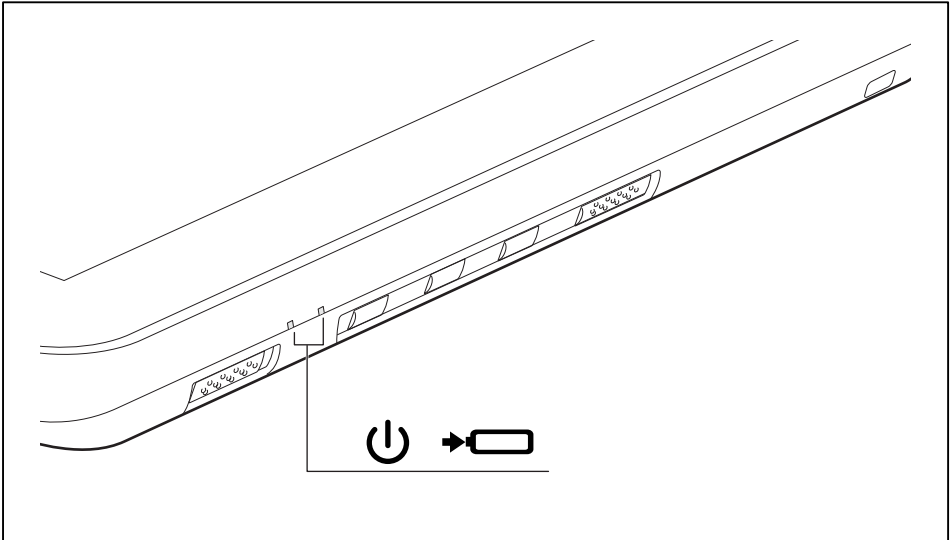
The status indicators provide information about the status of the power supply, the drives and the keyboard functions etc.



Status displays	Description
	Power-on indicator <ul style="list-style-type: none"> The indicator is illuminated: The Tablet PC is switched on. The indicator is flashing: The Tablet PC is in sleep mode (Save-to-RAM). The indicator is not illuminated: The Tablet PC is switched off or in Save-to-Disk mode.
	Battery charging indicator The battery charging indicator shows whether a battery is installed and being charged.

Switching on the Tablet PC

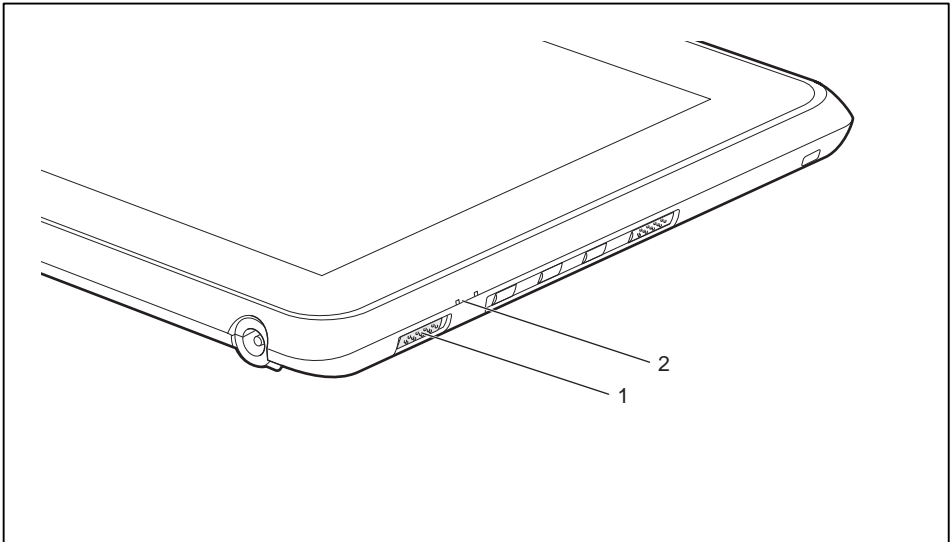

- ▶ Slide the ON/OFF switch (1) to the right to switch on the Tablet PC.
- ↳ The ON/OFF switch returns automatically to its original position.
- The power-on indicator (2) lights up whenever the system is switched on.

Programming the ON/OFF switch

You can program the ON/OFF switch:

Operating system	Menu
Windows 7	<i>Start - (Settings) - Control Panel - System and Security - Power Options</i>

i

If you have assigned a password, you must enter this when requested to do so, in order to start the operating system. Detailed information can be found in the chapter ["Security functions", Page 53](#).

Switching off the Tablet PC

- ▶ Close all applications and then shut down the operating system (please see the "Operating System Manual").
- ▶ Slide the ON/OFF switch towards the right.
- ↳ The ON/OFF switch returns automatically to its original position.

Handwriting recognition under Windows 7

Handwriting recognition under Windows 7 currently supports the following languages:

English, German, French, Italian, Japanese, Korean, Chinese (traditional and simplified), Dutch, Portuguese, Spanish, Brazilian, Norwegian (Bokmål and Nynorsk), Swedish, Finnish, Danish, Polish, Rumanian, Serbian (Cyrillic and Latin script), Catalan, Russian, Czech and Croatian.

Touchscreen

High-quality TFT displays are installed in Tablet PCs from Fujitsu Technology Solutions GmbH. For technical reasons, TFT monitors are manufactured for a specific resolution. An optimal, clear picture can only be ensured with the correct resolution intended for the relevant TFT monitor. A monitor resolution which differs from the specification can result in an unclear picture.

The screen resolution of your Tablet PC's touchscreen is optimally set at the factory.

The standard of production techniques today cannot guarantee an absolutely fault-free screen display. A few isolated constant lit or unlit pixels (picture elements) may be present. The maximum permitted number of pixels faults is stipulated in the international standard ISO 9241-3 (Class II).

Example:

A monitor with a resolution of 1280 x 800 has $1280 \times 800 = 1024000$ pixels. Each pixel consists of three subpixels (red, green and blue), so there are almost 3 million subpixels in total. According to ISO 9241-3 (class II), a maximum of 2 light and 2 dark pixels and an additional 5 light or 10 dark subpixels or a corresponding mix may be defective (1 light subpixel counts as 2 dark subpixels).

Pixel	A pixel consists of 3 subpixels, normally red, green and blue. A pixel is the smallest element that can be generated by complete functionality of the display.
Subpixel	A subpixel is a separately addressable internal structure within a pixel that enhances the pixel function.
Cluster	A cluster contains two or more defective pixels or subpixels in a 5 x 5 pixel block.

Background lighting

TFT monitors are operated with background lighting. The luminosity of the background lighting can decrease while the Tablet PC is in use. However, you can set the brightness of your monitor individually.

Synchronising the display on the touchscreen and an external monitor

In Windows 7, you can switch between touchscreen and external monitor, if you open *Control Panel - Windows Mobility Center*, section *External Display*.

Select display orientation (portrait or landscape orientation)

You can choose to use either portrait or landscape orientation for the display. Press the Tablet button  to switch between portrait and landscape orientation.



Windows 7

You can change these settings in the Fujitsu menu or under *Start - (Settings -) Control Panel - Hardware and Sound - Display - Settings*.



Profiles for operating with various different screen modes can be selected via the *Fujitsu Tablet Control* option in the Fujitsu menu. These profiles have preset standard configurations that can be modified as desired.

These settings do not just affect the monitor settings on the Tablet PC, but also any external monitors that may be connected.

Using fingers

You can execute certain commands by using your finger tip on the touchscreen of your device.



Everything which you can select or activate using your finger tip can also be selected or activated using the stylus pen.

Calibrate the Dual Digitizer for finger-based operation of the device.



Before operating the device for the first time using the fingers, you must calibrate it so that your finger tips are recognized as accurately as possible.

You must calibrate the device again as soon as you notice that the variations are becoming greater.

Operating system	Menu
Windows 7	To calibrate, call up the <i>Hardware and Sound / Tablet PC Settings</i> function in the Control Panel. You need to calibrate both portrait and landscape formats.

Actions with one finger

Action	Description
Selecting objects (click with the left mouse button)	<ul style="list-style-type: none"> ▶ With your finger, tap once briefly on the object.
Starting programs (double-click with the left mouse button)	<ul style="list-style-type: none"> ▶ With your finger, tap twice briefly in quick succession on the program icon.
Moving objects/windows (drag with left mouse button pressed, Drag & Drop)	<div data-bbox="588 363 1008 582" data-label="Image"> </div> <ul style="list-style-type: none"> ▶ Place a finger directly on the object/window, hold the finger pressed against the touchscreen and move the desired object/window.
Opening a context menu (click with the right mouse button)	<ul style="list-style-type: none"> ▶ Touch the desired item once with your finger tip. Keep the finger tip pressed against the touchscreen. <p>The context menu appears.</p>
Moving the cursor	<ul style="list-style-type: none"> ▶ Position one finger on the touchscreen and move the finger in the desired direction.

Actions with two fingers

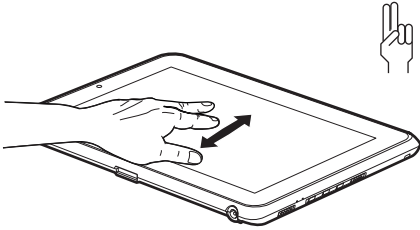
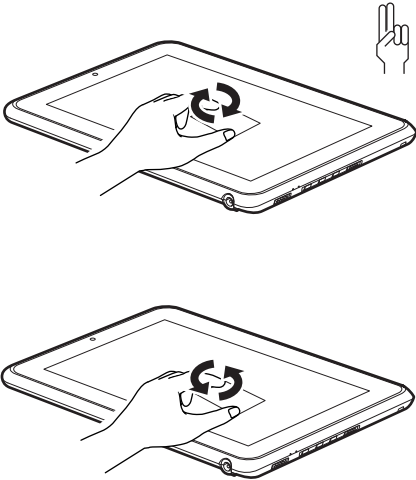
Action	Description
Scrolling	 <ul style="list-style-type: none">▶ Position two fingers on the touchscreen.▶ Move your fingers upwards to scroll up. or <ul style="list-style-type: none">▶ Move your fingers downwards to scroll down.
Rotating	 <ul style="list-style-type: none">▶ Position the thumb on the touchscreen, then turn the picture clockwise or counter-clockwise using your index finger.

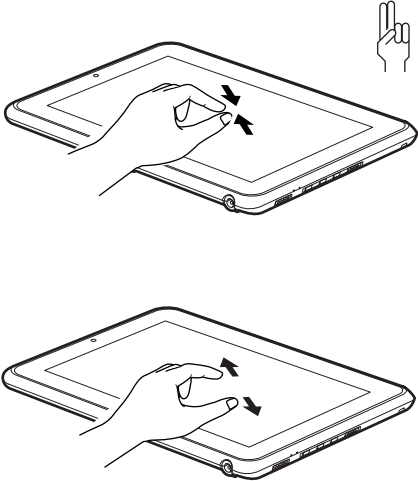
Action	Description
Increasing or decreasing the view	 <ul style="list-style-type: none">▶ Position two fingers on the touchscreen and move them apart to increase the view. or <ul style="list-style-type: none">▶ Position two fingers on the touchscreen and move them together to decrease the view.
Blocking context-sensitive menus	<ul style="list-style-type: none">▶ With two fingers, tap twice briefly in quick succession on the touchscreen.

Actions with three fingers

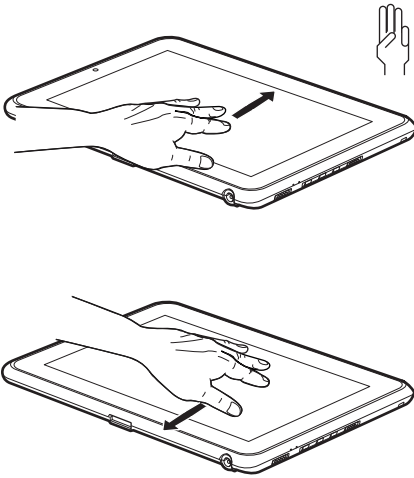
Action	Description
Maximising or minimising current window	 <p>The diagram shows two illustrations of a hand interacting with a tablet PC. In the top illustration, three fingers (index, middle, and ring) are positioned on the screen, and an upward-pointing arrow indicates the direction of movement to maximize the window. In the bottom illustration, the same three fingers are positioned on the screen, and a downward-pointing arrow indicates the direction of movement to minimize the window. A small icon of a hand with three fingers extended is located in the top right corner of the description area.</p> <ul style="list-style-type: none">▶ Position three fingers on the touchscreen and move them upwards to maximise the window.or▶ Position three fingers on the touchscreen and move them downwards to minimise the window.

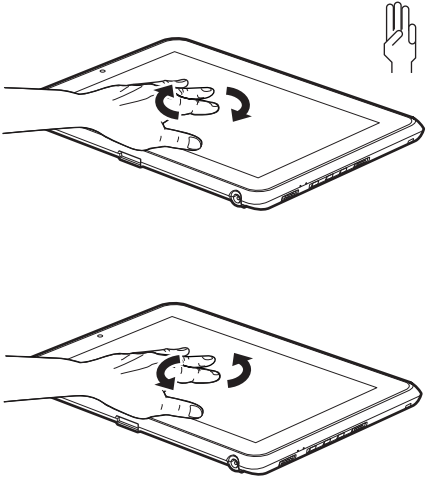
Action	Description
Displaying and rotating current window in 3D carousel layout	 <ul style="list-style-type: none">▶ Tap the touchscreen with your three fingers to display the 3D carousel.▶ Hold your fingertips pressed to change the 3D carousel layout.
Minimising all windows and displaying the desktop	<ul style="list-style-type: none">▶ With three fingers, tap the touchscreen twice briefly in quick succession.

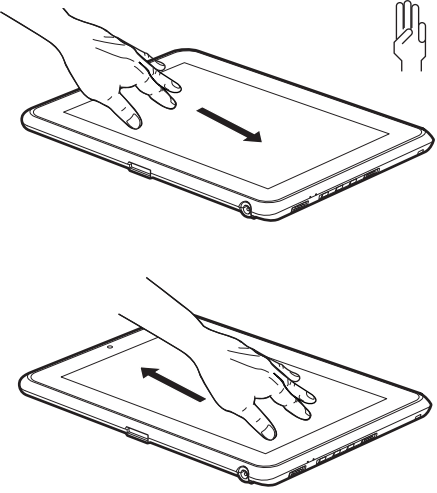
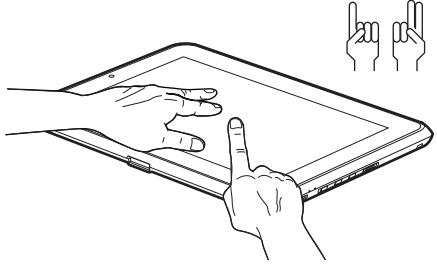
Action	Description
Scrolling through all open files in a program	 <ul style="list-style-type: none">▶ Position three fingers on the touchscreen and move them to the side (left or right) over the touchscreen.
Displaying context menu and selecting entry	 <ul style="list-style-type: none">▶ Position two fingers on the touchscreen. A context menu is displayed on the screen.▶ With one finger on the other hand, tap on an entry in the context menu. The entry is selected.

Actions with four fingers

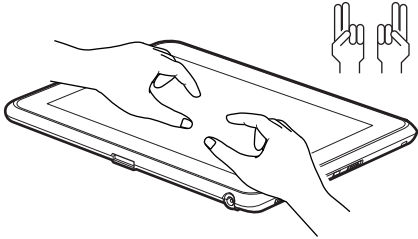
Action	Description
<p>Displaying a menu with context-sensitive web applications with one hand</p> <p>You can select a word, sentence, paragraph or an item</p>	<ul style="list-style-type: none">▶ Tap briefly on the touchscreen with four fingers on one hand then lift your fingers from the screen. <p>A menu with context-sensitive web applications is displayed.</p>
<p>Displaying menu with context-sensitive web applications with two hands</p>	 <p>The diagram illustrates two actions. The top part shows a hand tapping a tablet with four fingers. The bottom part shows two hands framing a rectangular area on a tablet screen, with a callout showing two hands with two fingers each pointing to the corners of the rectangle.</p> <ul style="list-style-type: none">▶ To select an area, position two fingers of each hand in a rectangle on the touchscreen as shown. <p>A menu with context-sensitive web applications is displayed.</p>

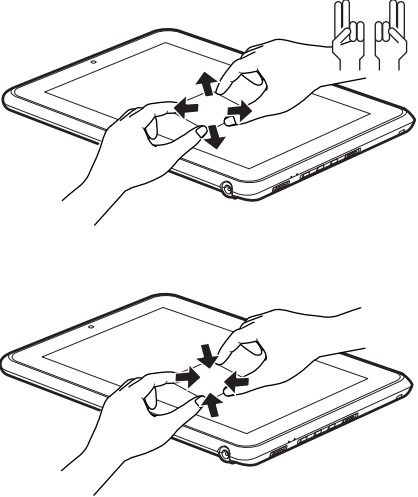
Action	Description
Enlarging the area	 <ul style="list-style-type: none">▶ To magnify an area of a document, position two fingers of each hand in a rectangle on the touchscreen as shown. The selected area will be magnified.▶ Place one finger on the touchscreen to move the rectangle around the touchscreen to magnify several areas.

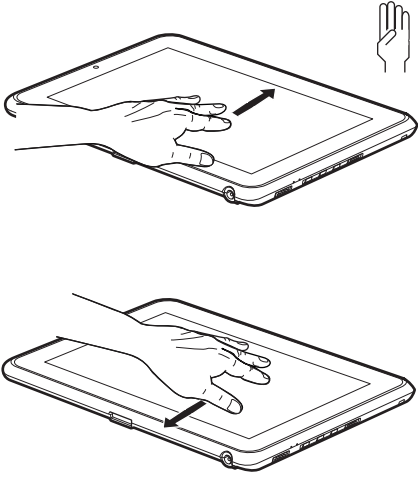
Action	Description
Paging through (fast scrolling)	 <ul style="list-style-type: none">▶ Position four fingers on the touchscreen and move them upwards to scroll up. <p>or</p> <ul style="list-style-type: none">▶ Position four fingers on the touchscreen and move them downwards to scroll down. <p>The distance you sweep your fingers indicates how far you move up or down.</p>

Using the stylus pen

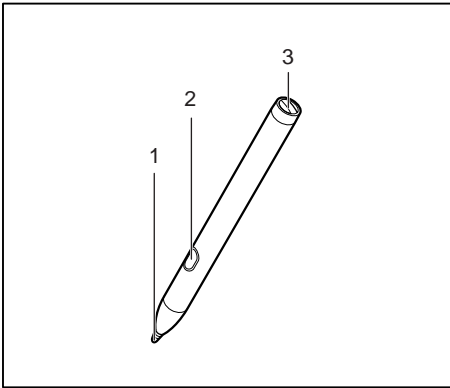

- 1 = pen tip
- 2 = pen button
- 3 = eyelet for pen cord

You can use the pen on your Tablet PC as an electronic writing implement to select items, and to navigate through programs on it. Programs that support handwriting recognition also allow you to write characters directly on the screen with the pen. You can also use the pen as a drawing tool.

The pen is retained securely in the pen slot. This ensures that the pen cannot be lost, regardless of whether you use the Tablet PC or transport it while travelling. Always replace the pen in its slot when you are not using it.

The Tablet PC is supplied with a pen cord which you can attach to the eyelets on the pen and on the Tablet PC.



Use only the pen provided with your Tablet PC. Do not use substitutes that were not designed for your Tablet PC. Replace the stylus tip if it is worn. The warranty does not cover a scratched screen.

While writing, you should take care not to scratch the surface of the display (e.g. with a wristwatch or bracelet).



The Tablet PC's pen is an electronic instrument that can be damaged if used improperly. Handle the pen with care.

The following list contains guidelines for proper pen handling:

- Do not gesture with the pen.
- Do not use the pen as a pointer.
- Do not use the pen on surfaces other than the screen of the Tablet PC.
- Do not try to turn the thumb grip on the pen. The thumb grip is used to place the pen in its slot and to take it out of the slot.
- Never store the pen with the tip bearing the weight of the pen (e.g. with the tip down in a pen holder). If the pen is stored with the tip pointing down, this may have an adverse effect on the pen mechanism (particularly under high temperatures). In this case the pen tip may react as though it is constantly being pressed down. To avoid damage, the pen should be stored in the pen slot when not in use.

The pen can be influenced by electromagnetic fields (cursor quivers or jumps). There may be a few areas on the screen where the cursor quivers slightly in spite of pressing the pen down firmly.

The screen responds to entries made with the tip of the finger or the pen when the tip of the finger or the pen is in direct contact with the screen.

You can use the pen to run all functions for which you would otherwise use a mouse.

The pen does not support erasing functions.

Handling	Mouse	Pen
Selecting menu items	Click with the left-hand mouse button.	Touch the menu entry with the pen tip.
Starting programs	Double click with the left-hand mouse button.	Briefly touch the program icon twice with the pen tip.
Moving an object/window	Drag with the left-hand mouse button held pressed.	Place the pen tip directly on the object/window. Hold the pen tip pressed against the screen. Move the desired object/window.
Opening a context menu	Click with the right-hand mouse button.	Place the pen directly on the required element and hold the pen pressed against the screen.
Moving the cursor	-	Place the pen tip directly on the screen.

Setting the pen

Operating system	Menu
Windows 7	Under <i>Hardware and Sound – Pen and Input Devices</i> in the Control Panel you can change various settings for the pen (assignment and function of the pen button).

Calibrating the pen

Before using the pen for the first time, you should calibrate it so that the cursor follows the movements of the pen as accurately as possible. You should also always repeat the calibration if the co-ordination between the pen and cursor movement deteriorates.

Operating system	Menu
Windows 7	To calibrate, call up the <i>Hardware and Sound / Tablet PC Settings</i> function in the Control Panel. You need to calibrate both portrait and landscape formats.

Changing the pen tip

With use, the pen tip may become worn or may pick up foreign particles that can scratch the screen. A damaged or worn tip may not move freely, causing unpredictable results when using the pen.

If these problems appear with your pen, you should change the pen tip.

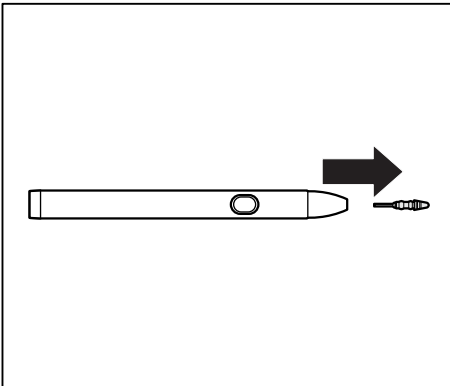

- ▶ Pull the pen tip from the pen.
- ▶ Replace the pen tip with one of the replacement tips that were supplied your pen. Insert the pointed end of the pen tip into the barrel and push it in gently until it is in place.

i

Do not continue to use a tip which is worn or damaged.

Removing the pen battery



Do not take off the pen tip to change the battery.

The pen contains one AAAA battery.

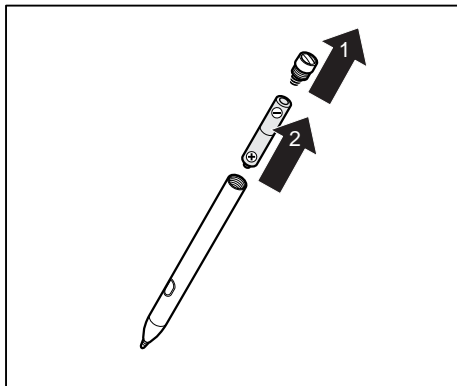

- ▶ Unscrew and remove the cap from the pen (1).
- ▶ Pull the battery out of the pen (2).

Installing a pen battery

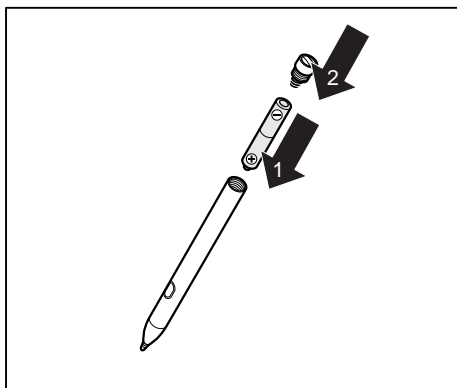

- ▶ Insert the new battery in the pen (1).
- ▶ Close the pen cap (2).

Installing a pen cord

You should attach the pen with a pen cord to prevent accidentally dropping or losing it.

- ▶ Fasten the pen cord to the pen eyelet and to the eyelet on the Tablet PC.

Tablet buttons

Your Tablet PC is fitted with three multi-functional tablet keys. You can navigate on the screen with a simple press of a button, call preset applications or ones that you have set yourself.

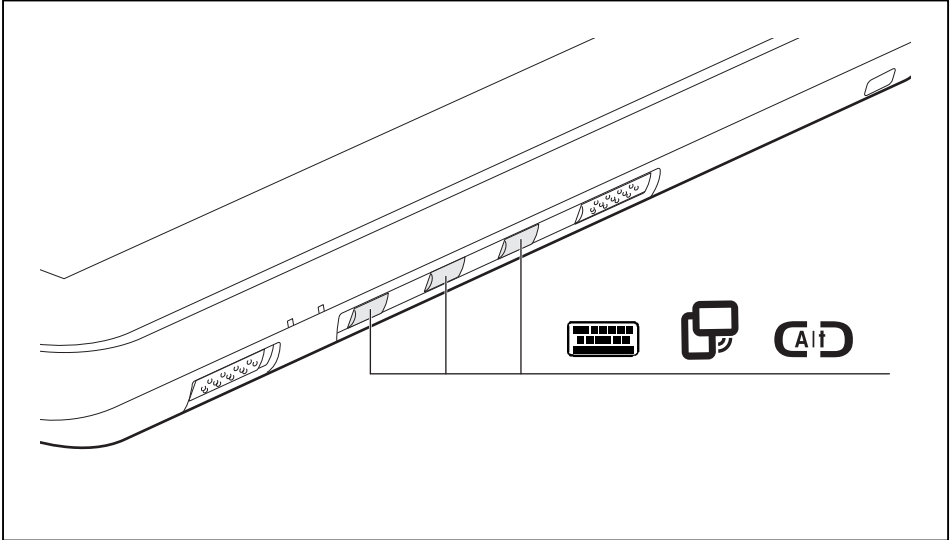



Basic functions before the device has booted

i



You can configure the functions in the table below yourself.

The *TPM PPI* (Physical Presence Interface) menu is available only if your system has a TPM module.

The *TPM PPI* menu is displayed after the security condition for the TPM running under Windows has been changed.

Key	Function, if the key is pressed while booting the system	Function in application menu/boot menu/BIOS setup	Function in <i>TPM PPI</i> menu
	F1 (application menu)	High	—
	F2 (BIOS setup)	Low	Yes
	F12 (Boot menu)	Input	No

Basic functions when the device has booted

Button	Basic function
	<p>Log on to the system or open the Windows Task Manager</p> <p>If you keep this tablet button pressed for two seconds, you can log back onto the system again:</p> <ul style="list-style-type: none">• after system startup• after a system lock• when returning from power management <p>After log-on, pressing the tablet button for two seconds launches the Windows Task Manager or - in the network - opens the security window.</p>
	<p>Change screen orientation</p> <p>When you press this tablet button, the orientation of the screen display changes from portrait (vertical) to landscape (horizontal) or vice versa.</p> <p>If you wish to use the Tablet PC as an eBook, you should use the portrait orientation.</p> <p>When accessing spreadsheets, you would more typically use a landscape orientation.</p>
	<p>Tap: Monitor keyboard</p> <p>If you tap this tablet key, the monitor keyboard is displayed.</p> <p>Hold down: Calls up the Fujitsu menu</p> <p>If you hold this tablet key down, the <i>TouchLauncher</i> appears on your screen. Use the <i>TouchLauncher</i> to run the installed programs.</p> <p>When you press this tablet button and keep it held, the Fujitsu menu appears on your screen. The Fujitsu Menu is used to change certain system settings.</p>

Programming the tablet buttons

You can program the tablet buttons to open a specific application or execute a specific function when pressed.

Proceed as follows:

- ▶ In Control Panel, select the option to manage the settings for the tablet buttons and pen.
- ▶ Follow the instructions on the screen and program the tablet buttons as you require.

Webcam



Your device has two WebCams: one on the front side of the device and one on the rear.

Depending on the software used, you can use your Webcam to take pictures, record video clips or take part in web chats.

- The picture quality depends on the lighting conditions and the software being used.
- You can only operate the webcam with a particular application (e.g. an Internet telephony program or a video conferencing program which supports a webcam).
- When using the webcam the Tablet PC support must not wobble.
- The webcam automatically adjusts itself to the current light level. For this reason the touchscreen may flicker while the light level is adjusted.



Further information on using the webcam and on the additional settings which are possible for your webcam can be found in the help function of the program which uses the webcam.

If you wish to carry out a function test with your webcam, you can use the corresponding test software available at ["http://ts.fujitsu.com/support/"](http://ts.fujitsu.com/support/).

Rechargeable battery

For mobile use, the built-in battery provides the Tablet PC with the necessary power. You can increase the life of the battery by caring for the battery properly. The average battery life is around 500 charge/discharge cycles.

You can extend the battery life by taking advantage of the available energy saving functions.

Charging, caring for and maintaining the battery

The Tablet PC battery can only be charged when the ambient temperature is between 5°C and max. 35°C.

You can charge the battery by connecting the Tablet PC to the mains adapter (see ["Mains adapter connecting", Page 18](#)).

If the battery is running low you will hear a warning alarm. If you do not connect the mains adapter within five minutes of the warning alarm described above, your Tablet PC will switch off automatically.

monitoring the battery charging level

Windows also has a "Battery status meter" in the taskbar for monitoring the battery capacity. When you place the mouse pointer on the battery symbol, the system displays the battery status.

Battery storage

Keep the battery pack between 0°C and +30°C. The lower the temperature at which the batteries are stored, the lower the rate of self-discharge.



If you will be storing batteries for a longer period (longer than two months), the battery charge level should be approx. 30 %. To prevent exhaustive discharge which would permanently damage the battery, check the level of charge of the battery at regular intervals.

To be able to make use of the optimal charging capacity of the batteries, the battery should be completely discharged and then fully recharged.



If you do not use the batteries for long periods, remove them from the Tablet PC. Never store the batteries in the device.

Removing and installing the battery



Only use batteries approved by Fujitsu Siemens Computers for your Tablet PC.

Never use force when fitting or removing a battery.

Make sure that no foreign bodies get into the battery connections.

Never store a battery for longer periods in the discharged state. This can make it impossible to recharge.

Removing the battery



Please observe the safety information in chapter ["Important notes", Page 11](#).

Remove the power plug from the mains outlet!

- ▶ Switch the device off.



The device must not be in energy-saving mode.

- ▶ Remove all the cables from the device.
- ▶ Turn the device over and place it on a stable, flat and clean surface. If necessary, lay an anti-slip cloth on this surface to prevent the device from being scratched.

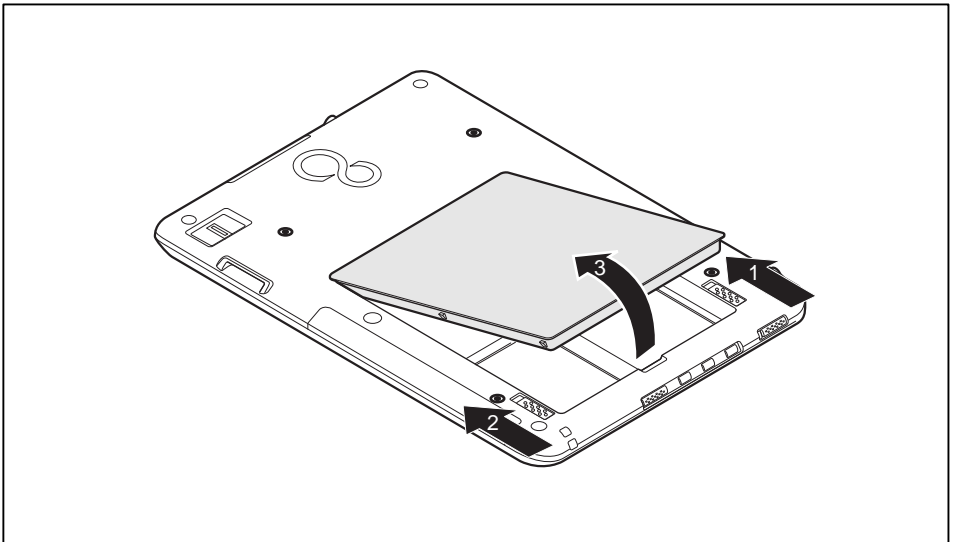

- ▶ Slide the release button in the direction of the arrow (1).
- ▶ Slide the release button in the direction of the arrow (2) and hold it in place.
- ▶ Remove the battery from the battery compartment (3).

Installing battery

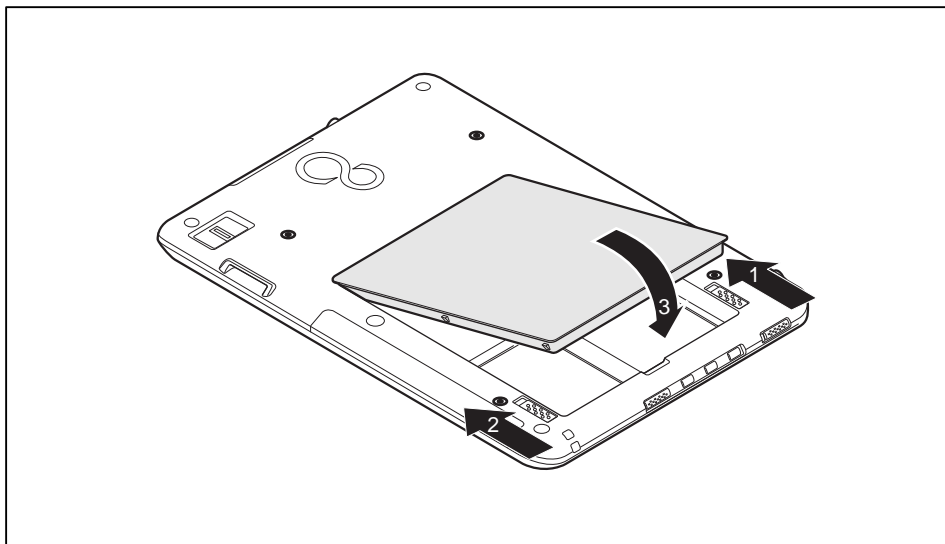

- ▶ Slide the release button in the direction of the arrow (1).
- ▶ Slide the release button in the direction of the arrow (2) and hold it in place.
- ▶ Push the battery into the battery compartment until you feel it engage (3).

Using the power-management features

The Tablet PC uses less power when the power management features are enabled. You will then be able to work longer when using the battery before having to recharge it.



Power efficiency is increased and environmental pollution reduced. By choosing the best power options, you can make significant savings and at the same time help protect the environment.

We recommend the following settings:

Function	On external power	On battery power
Turn off monitor	After 10 minutes	After 5 minutes
Turn off hard disk(s)	After 15 minutes	After 10 minutes
Energy saving (S3)	After 20 minutes	After 15 minutes
Hibernate mode (S4)	After 1 hour	After 30 minutes

- ▶ Select the power management functions in your Control Panel.
- ▶ Select the Screen Saver in your Control Panel.

or

- ▶ Keep a finger pressed on the desktop. Configure the screensaver under *Personalization - Change screensaver*.



If you need further information about an option, you can get help with most settings by pressing the symbol in the upper right of the screen to open the Microsoft Help.

When the Tablet PC is in power saving mode, you must remember the following:



During power saving mode, open files are held in the main memory or in a swap file on the hard disk.

Never switch off the Tablet PC while it is in a power saving mode. If the built-in battery is nearly flat, close the open files and do not go into power saving mode.

If you do not intend to use your Tablet PC for a long period of time:

- ▶ Exit the power saving mode if necessary via touching the screen or by switching on the Tablet PC.
- ▶ Close all opened programs and completely shut down the Tablet PC.

Memory cards

Your Tablet PC is equipped with an integrated memory card reader.



Observe the manufacturer's instructions when handling the memory cards.

Supported format

The memory card reader supports the following format:

- Secure Digital (SD™ card)

Inserting the memory card

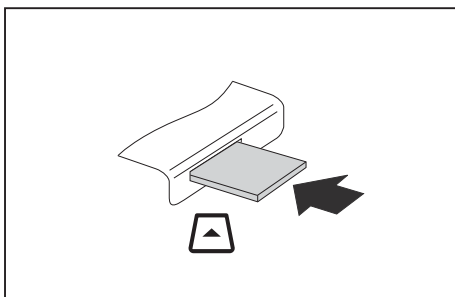

- ▶ Carefully slide the memory card into the slot. The label should be facing upward. Do not apply excessive force, as otherwise the delicate contact surfaces could be damaged.
- ↳ Depending on the particular type used, the memory card may protrude slightly from the slot.

Removing the memory card



In order to protect your data, always follow the correct procedure for removing the card outlined below.

You can stop the memory card via the corresponding icon in the task bar:

- ▶ Tap on the symbol.
- ▶ Select the card you want to stop and remove.
- ▶ Tap *OK*.
- ↳ Wait for the dialogue box which tells you that it is now safe to remove the memory card.

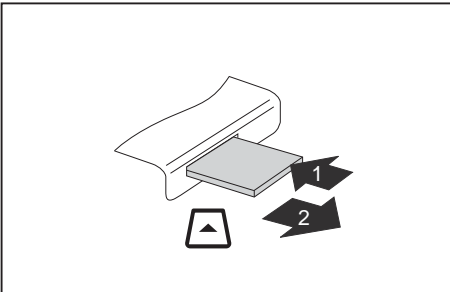

- ▶ On devices with card locking: Press on the storage card (1).
- ↳ The storage card is released and can now be removed.
- ▶ Pull the storage card out of the slot (2).

SIM card

A SIM Card (Subscriber Identity Module) is a chip card which is inserted in a mobile telephone or Tablet PC and, together with an integrated UMTS module, enables access to a mobile radio network.



When handling SIM cards, follow the instructions supplied by the provider.

Inserting the SIM card

- ▶ Remove the battery, see Chapter ["Removing the battery", Page 41.](#)

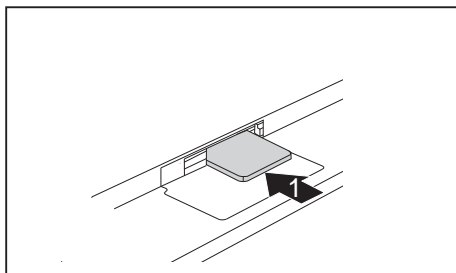

- ▶ Slide the SIM card into the slot (1) until it engages, as shown in the battery compartment. The notch shows to the left, the chip to the bottom.

- ▶ Install the battery again, see Chapter ["Installing battery", Page 42.](#)

Removing a SIM card

- ▶ Remove the battery, see Chapter ["Removing the battery", Page 41.](#)

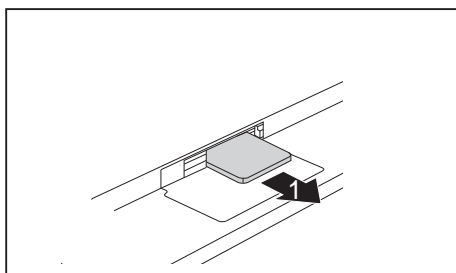

- ▶ Press on the edge of the SIM card so that it jumps up slightly out of the slot.
- ▶ Pull the SIM card out of the slot in the direction of the arrow (1).

- ▶ Install the battery again, see Chapter ["Installing battery", Page 42.](#)

Wireless LAN / Bluetooth / UMTS



The installation of radio components not approved by Fujitsu Technology Solutions will invalidate the certifications issued for this device.

Switching the wireless components on and off



Before switching on your device for the first time, the on/off switch for radio components must be in the "ON" position.

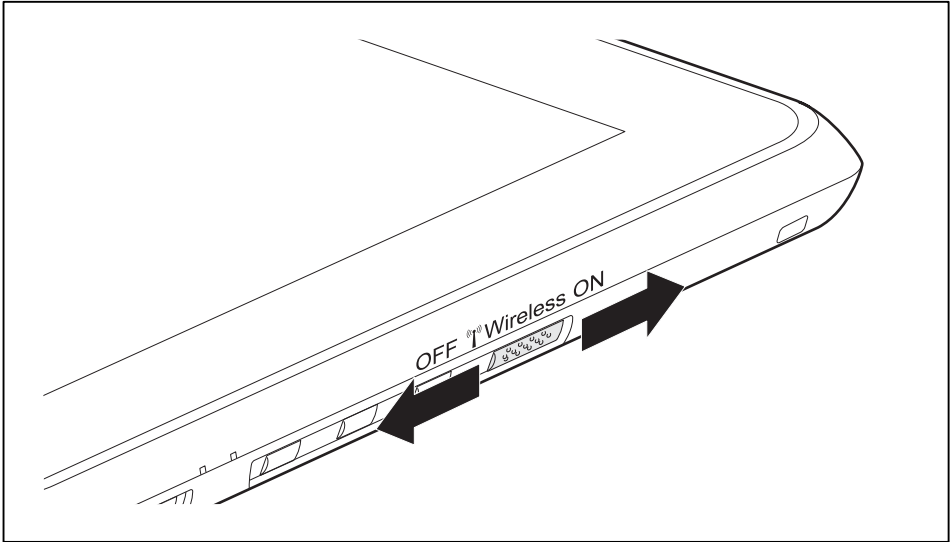

► Slide the ON/OFF switch into the "ON" position to activate the radio components.

or

► Slide the ON/OFF switch to the "OFF" position to deactivate the radio components.



If you switch off the radio components, the wireless LAN transmission unit (antenna) and, if present, the Bluetooth and UMTS module will also be switched off.

You can enable and disable the installed radio components individually using the *WirelessSelector* programme

You can also deactivate the wireless components individually in the *BIOS Setup*. For this to occur, you must either not have assigned a supervisor password or if a supervisor password has been assigned, you must know this password.

Pay attention to the additional safety notes for devices with radio components provided in the "Safety/Regulations" manual.

Details on using Wireless LAN can be found in the online help system included in the Wireless LAN software.

You can find more information on how to use Bluetooth on the CD you received with your Bluetooth software.

You can obtain more information on UMTS from your service provider.

Setting up WLAN access

- Requirement: A WLAN must be available and you must have the corresponding access information.



Information on configuring the WLAN access can be found in the documentation for your operating system.

Access via UMTS

If you ordered an integrated UMTS module with your system, you can enjoy optimum reception and maximum energy efficiency without awkward cables or antennas. The optional UMTS module is ready for use straight away.

If you did not order a UMTS module, you can purchase the accessories for UMTS reception from your retailer or your Fujitsu Technology Solutions dealer.

You will find information on establishing the connection with the UMTS network in the documentation for the hardware used.

You can connect your device with the Internet via UMTS. To do this, use one of the following types of connection:

- a USB dongle (a USB stick with your mobile phone provider's SIM card)
- mobile end-device (e.g. mobile phone with Bluetooth or cable connection)

GPS



Whether or not your device has this function depends on the selected device expansion stage.

If your device is equipped with an integrated GPS module, you can use your device as a navigation system with the help of a corresponding software programme.

Your Cradle (optional)

Your Cradle is a device that helps you to quickly connect your Tablet PC to your peripheral devices, such as a printer, mouse, etc.

You only need to dock the Tablet PC in order to work with your peripheral devices.

Cradle components

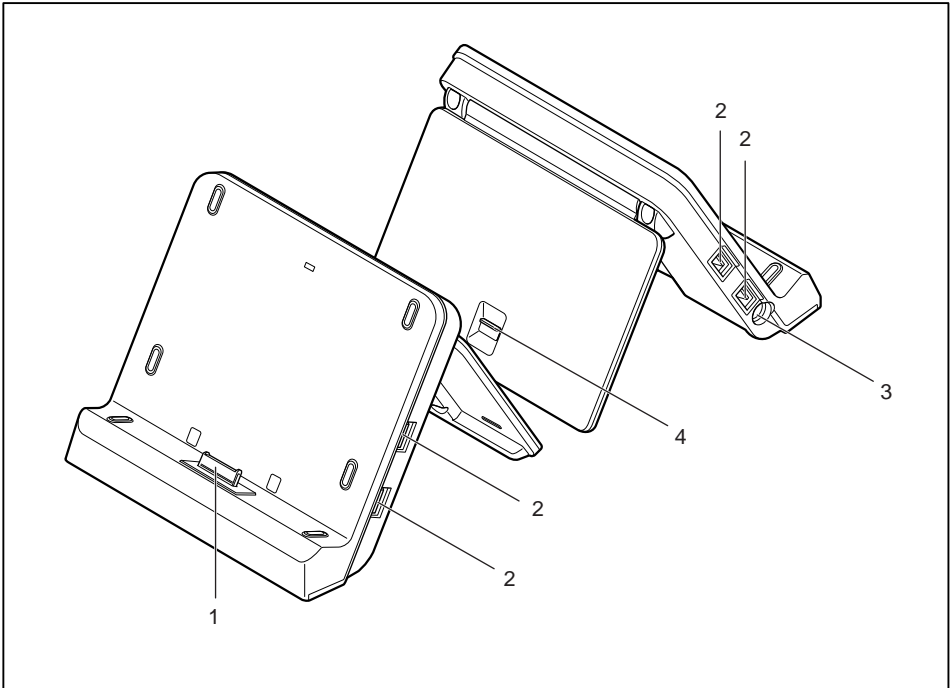

1 = Connector on the Cradle for the docking port of the Tablet PC

2 = USB ports

3 = DC input connector (DC IN)

4 = Unlocking lever

Setting up the Cradle



Select a suitable location for the Cradle before setting it up. Follow the instructions below when doing so:

- Place the Cradle on a flat, stable, nonslippery surface.
- Never place the Cradle and the mains adapter on a heat-sensitive surface.
- Do not expose the Cradle to extreme environmental conditions.
Protect the Cradle from dust, humidity and heat.

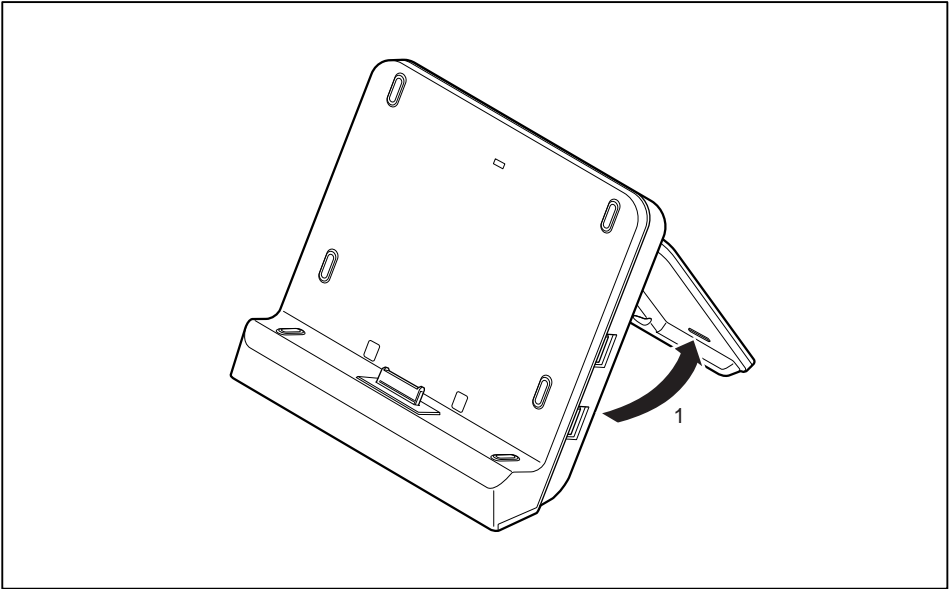

- ▶ Press the release lever and unfold the Cradle's stand from (1), until it engages in its final position

Connecting the Tablet PC to the Cradle



If you connect the Tablet PC to the Cradle during operation, problems can occur. We recommend that you switch off the Tablet PC beforehand.



If the Tablet PC is connected to the Cradle, you must connect the mains adapter to the Cradle.

- ▶ Switch off the Tablet PC.

- ▶ Remove the power plug of the mains adapter from the mains socket.
- ▶ Pull the mains adapter cable out of the DC jack (DC IN) of the Tablet PC.

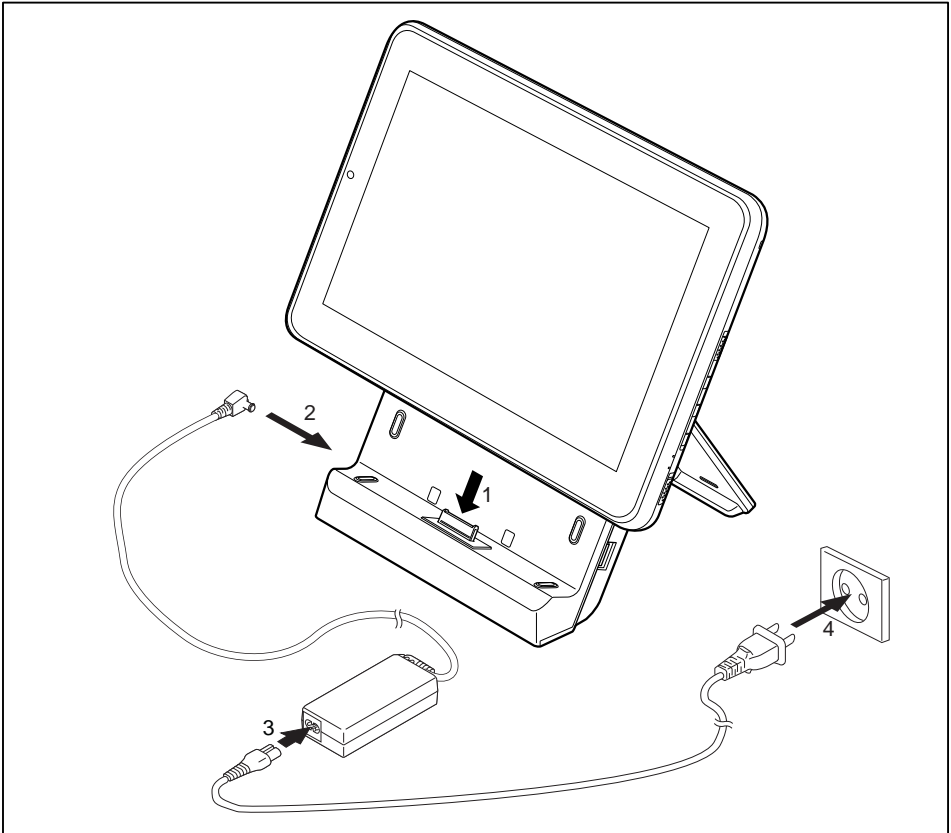

- ▶ Position the Tablet PC so that it is in line with the storage space of the Cradle.
- ▶ Push the Tablet PC on to the Cradle in the direction of the arrow (1) until you notice it engage with the plug.
- ▶ Plug the DC output connector on the mains adapter into the DC input connector (DC IN) on the Cradle (2).
- ▶ Connect the power cable to the mains adapter (3).
- ▶ Plug the power cable into the mains socket (4).
- ▶ Close the clip on the rear side of the Cradle.

Disconnecting the Tablet PC from the Cradle



If you connect the Tablet PC to the Cradle during operation, problems can occur. We recommend that the Tablet PC is switched off or that the appropriate undocking function provided by the operating system is executed.

- ▶ Switch off the Tablet PC.
- ▶ Open the clip on the rear side of the Cradle.

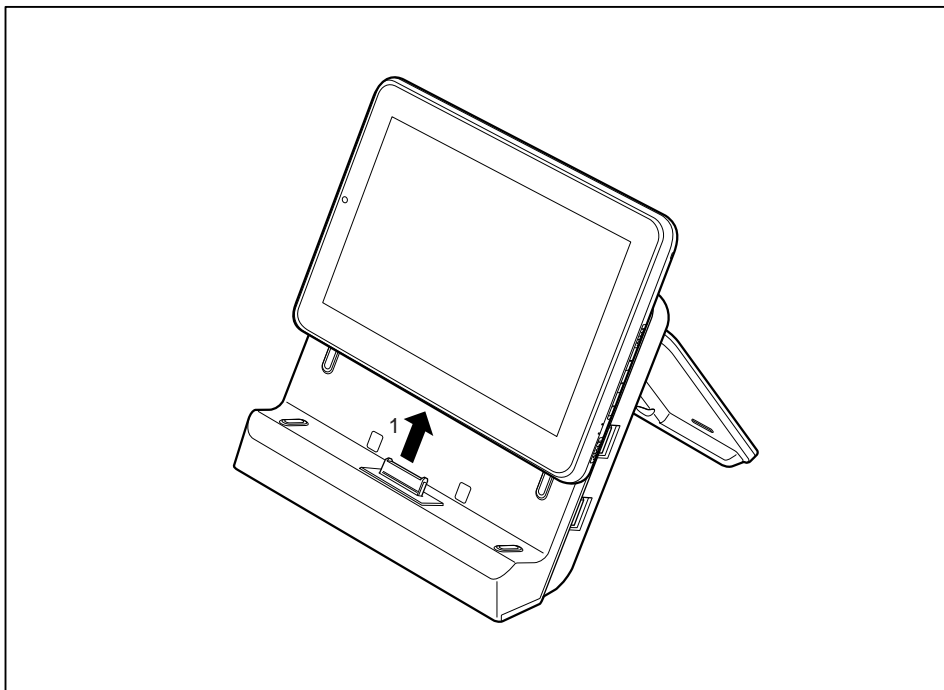

- ▶ Lift the Tablet PC from the Cradle in the direction of the arrow (1), while supporting the underneath of the Cradle.

Security functions

Your Tablet PC has several security features that you can use to secure your system from unauthorised access.

This chapter explains how to use each function, and what the benefits are.



Please remember that in some cases, for example, forgetting your password, you may be locked out and unable to access your data. Therefore, please note the following information:

- Make regular backups to external data carriers such as external hard drives, CDs, DVDs or Blu-ray Discs.
- Some security functions need you to choose passwords. Make a note of the passwords and keep them in a safe place.

If you forget your passwords you will need to contact our Service Desk. Deletion or resetting of passwords is not covered by your warranty and a charge will be made for assistance.

Configuring the fingerprint sensor

The fingerprint sensor can record an image of a fingerprint. With additional fingerprint software, this image can be processed and used instead of a password.

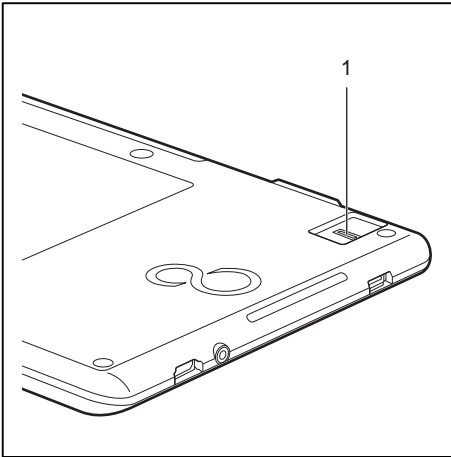

- You must install the fingerprint software in order to be able to use the fingerprint sensor (1).

Configuring password protection in BIOS Setup Utility



To navigate more easily in the *BIOS Setup Utility*, you can use an external USB keyboard.



Before using the various options for password protection in the *BIOS Setup utility* to increase data security, please observe the following:

Make a note of the passwords and keep them in a safe place. If you forget your supervisor password you will not be able to access your Tablet PC. Passwords are not covered by your warranty and a charge will be made for assistance.



Your password can be up to eight characters long and contain letters and numbers. No distinction is made between uppercase and lowercase.

Protecting BIOS Setup Utility (supervisor and user password)



If you have opened these operating instructions on the screen, we recommend that you print out the following instructions. Because you cannot call the instructions onto the screen while you are setting up the password.

You prevent unauthorised use of the *BIOS Setup Utility* with both the supervisor and the user password. The supervisor password gives you access to all functions of the *BIOS Setup Utility*, while the user password only provides some of the functions. You can only set a user password if a supervisor password has already been assigned.



Please refer to the [""Settings in BIOS Setup Utility", Page 64](#) section for a description of how to call up and operate the *BIOS Setup Utility*.

Setting supervisor and user password

- ▶ Start the *BIOS Setup Utility* and go to the *Security* menu.
- ▶ Select the *Set Supervisor Password* field and press the Enter key.
 - ↳ With *Enter new Password*: you are asked to enter a password.
- ▶ Enter the password and press the Enter key.
 - ↳ *Confirm new Password* requires you to confirm the password.
- ▶ Enter the password again and press the Enter key.
 - ↳ *Changes have been saved* is a confirmation that the new password has been saved.
- ▶ To set the user password, select *Set User Password* and proceed exactly as when configuring the supervisor password.
 - ↳ If you do not want to change any other settings, you can exit *BIOS Setup Utility*.
- ▶ In the *Exit* menu, select the option *Save Changes & Exit*.
- ▶ Select *Yes* and press the Enter key.
 - ↳ The Tablet PC is rebooted and the new password is effective. It will now be necessary to first enter your supervisor or user password in order to open the *BIOS Setup Utility*. Please note that the user password only provides access to a few of the BIOS settings.

Changing the supervisor or user password

You can only change the supervisor password when you have logged into the *BIOS Setup Utility* with the supervisor password.

- ▶ Call the *BIOS Setup Utility* and go to the *Security* menu.
- ▶ When changing the password, proceed exactly as for password assignment.

Removing passwords

To remove a password (without setting a new password) perform the following steps:

- ▶ Start the *BIOS Setup Utility* and go to the *Security* menu.
- ▶ Highlight the *Set Supervisor Password* or *Set User Password* field and press the Enter key.
 - ↳ You will be requested to enter the current password by the *Enter Current Password* prompt. You will be requested to enter a new password by the *Enter New Password* prompt.
- ▶ Press the Enter key twice.
- ▶ In the *Exit* menu, select the option *Save Changes & Exit*.
- ▶ Select *Yes* and press the Enter key.
 - ↳ The Tablet PC is rebooted and the password is cancelled. Removing the supervisor password simultaneously deactivates the user password.

Password protection for booting of the operating system



With the supervisor password you have set in the *BIOS Setup Utility* (see section ["Setting supervisor and user password", Page 55](#)), you can also prevent booting of the operating system.

Activating system protection

- ▶ Start the *BIOS Setup Utility* and go to the *Security* menu.
- ▶ Select the *Password on Boot* option and press the Enter key.
- ▶ Select the desired option (*Disabled*, *First Boot* or *Every Boot*) and press the Enter key
- ▶ Select the *Save Changes & Exit* option under *Exit*.
- ↳ The Tablet PC reboots. You will be prompted to enter your password (the supervisor password).

Deactivating system protection

- ▶ Start the *BIOS Setup Utility* and go to the *Security* menu.
- ▶ Select the *Password on Boot* option and press the Enter key.
- ▶ Select the *Disabled* option and press the Enter key.
- ↳ If you do not want to change any other settings, you can exit *BIOS Setup Utility*.
- ▶ Select the *Save Changes & Exit* option under *Exit*.
- ↳ The Tablet PC reboots. The system is no longer password-protected.

Password protection for the hard disk



The hard disk password prevents unauthorised access to the hard disk drives and is checked internally each time the system is booted. The condition for this is that you have assigned at least the supervisor password.

Activating hard disk protection

- ▶ Call up the *BIOS Setup* and select the *Security* menu.
- ↳ If you have not assigned BIOS passwords yet, define the supervisor and the user password now, if desired (see ["Security functions", Page 53](#)).
- ▶ Mark the *Hard Disk Security* field and press the Enter key.
- ▶ In the *Drive0* area mark the *Set Master Password* field and press the Enter key.
- ↳ *Enter new Password* then appears and you are asked to enter a password.
- ▶ Enter the password and press the Enter key.
- ↳ *Confirm new Password* requires you to confirm the password.
- ▶ Enter the password again and press the Enter key.
- ↳ *Setup Notice: Changes have been saved* is displayed to confirm that the new password has been saved.
- ▶ To assign the password for the second hard disk (*Drive1*), go to the *Drive1* area and select the field *Set Master Password*, then proceed in exactly the same way as for setting up the password for the first hard disk (*Drive0*).
- ↳ The field *Password Entry on Boot* is set to *Enabled* by default. You can exit the *BIOS Setup* once you have finished changing the settings.
- ▶ From the *Exit* menu, choose the option *Exit Saving Changes*.
- ▶ Press the Enter key and select *Yes*.
- ↳ The Tablet PC reboots and your hard disk is now protected with a password. The password prompt is enabled as soon as the Tablet PC has rebooted.

Deactivating hard disk protection

To cancel a password without setting a new one, proceed as follows:

- ▶ Call up the *BIOS Setup* and select the *Security* menu.
- ▶ Mark the *Hard Disk Security* field and press the Enter key.
- ▶ In the *Drive0* area mark the *Set Master Password* field and press the Enter key.
- ↳ You will be initially requested to enter the old password by the *Enter current Password* prompt. You will then be requested to enter a new password by the *Enter new Password* prompt.
- ▶ After entering the password, press the Enter key three times.
- ▶ From the *Exit* menu, choose the option *Exit Saving Changes*.
- ▶ Press the Enter key and select *Yes*.
- ↳ The Tablet PC reboots and there is no longer any password protection for this hard disk.
- ▶ To cancel the password for the second hard disk (*Drive1*), go to the *Drive1* area and select the field *Set Master Password*, then proceed in exactly the same way as for cancelling the password for the first hard disk (*Drive0*).

SmartCard reader

SmartCards are not supplied as standard equipment. You can use all SmartCards that comply with the ISO standard 7816-1, -2 or -3. These SmartCards are available from various manufacturers.

With the appropriate software you can use your SmartCard as an alternative to password protection, but also as a digital signature, for encrypting your e-mails or for home banking.

We recommend that you always use two SmartCards. Always keep one of the SmartCards in a safe place if you are carrying the other SmartCard with you.

In order to be able to take advantage of all the security features of your Tablet PC, you will need a CardOS SmartCard from Fujitsu Technology Solutions.



The SmartCard can only be used with a PIN, offering maximum protection even if you lose the SmartCard. In order to maximise your security, the CardOS SmartCard is disabled if three incorrect attempts are made to enter the PIN.

When you use the CardOS SmartCard for the first time, you will either need to enter the preset PIN "12345678" or the PIN given to you by your systems administrator.

Inserting the SmartCard



Do not use force when inserting and removing the SmartCard.

Make sure that foreign objects do not fall into the SmartCard reader.

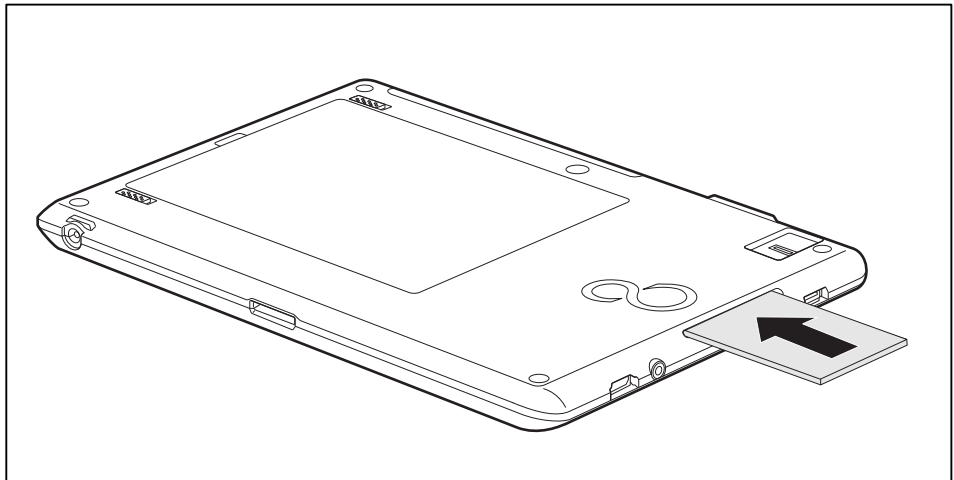

- ▶ Slide the SmartCard into the SmartCard reader with the chip facing upwards (on some variants it faces down) and to the front.

Trusted Platform Module (TPM) (device-dependent)

To use the TPM, you **must** activate the TPM in the *BIOS Setup* before the software is installed. The condition for this is that you have assigned at least the supervisor password (see "[Security functions](#)", [Page 53](#)).

Enabling TPM

- Requirement: You have assigned a supervisor password, see "[Security functions](#)", [Page 53](#).
- ▶ Call up the BIOS Setup and select the *Security* menu.
- ▶ Mark the *TPM Security Chip Setting* field and press the Enter key.
- ▶ Select *Enabled* to activate the TPM.
- ↳ Once you have activated the TPM the *Clear Security Chip* option appears.
Select *Clear Security Chip* to delete the holder in the TPM. By clicking on *Enabled*, all secret keys (e.g. SRK - Storage Root Keys, AIK - Attestation Identity Keys etc.) generated by applications are deleted.

Please note that you will then no longer be able to access the data you have encrypted with the keys based on that holder.
- ▶ Select the *Exit Saving Changes* option in the Exit menu.
- ▶ Press the Enter key and select *Yes*.
- ↳ The Tablet PC restarts and the TPM is switched on after the reboot.

Disabling TPM

- Requirement: You have assigned a supervisor password, see "[Security functions](#)", [Page 53](#).
- ▶ Call up the BIOS Setup and select the *Security* menu.
- ▶ Mark the *TPM Security Chip Setting* field and press the Enter key.
- ▶ Select *Disabled* to deactivate the TPM.
- ▶ From the *Exit* menu, choose the option *Exit Saving Changes*.
- ▶ Press the Enter key and select *Yes*.
- ↳ The Tablet PC is rebooted and the TPM is disabled.

Connecting external devices



Under all circumstances, please observe the safety notes provided in the ["Important notes"](#), [Page 11](#) chapter before connecting or disconnecting any devices to or from your Tablet PC.

Always read the documentation supplied with the device you wish to connect.

Never connect or disconnect cables during a thunderstorm.

Never pull at a cable when disconnecting it. Always grasp the plug.

Adhere to the order described below when you connect external devices to the Tablet PC or separate them from it:



With some devices, such as USB devices, it is not necessary to switch off the Tablet PC and the device before connecting/disconnecting. For more information about whether or not devices need to be switched off, please refer to the documentation supplied with the external device.

Some of the external devices require special drivers (see the operating system and external device documentation).

Connecting devices to the Tablet PC

1. Switch off the Tablet PC and all external devices.
2. Remove the mains plug for the Tablet PC and all relevant devices from the sockets.
3. Connect the cables for your external devices following the instructions.
4. Plug all power cables into the mains sockets.

Disconnecting devices from the Tablet PC

1. Switch off the Tablet PC and all external devices.
2. Remove the mains plug for the Tablet PC and all relevant devices from the sockets.
3. Disconnect the cables for your external devices following the instructions.

HDMI port

The HDMI port of your Tablet PC can be used to connect an external amplifier, LCD TV or a plasma TV with an HDMI connection.

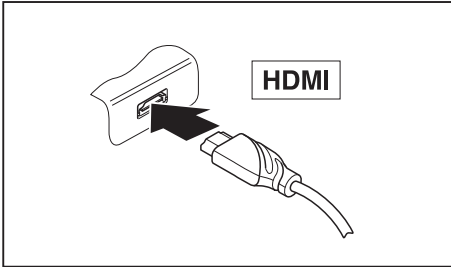

- ▶ Connect the data cable to the external device.
- ▶ Connect the data cable to the HDMI port of the Tablet PC.



Some LCD televisions have only two loudspeaker connections and therefore cannot reproduce Dolby digital or DTS. In order to reproduce the sound, you must go into *Windows* and adjust the sound settings.

Proceed as follows:

- ▶ Select *Startsymbol – (Settings) – Control Panel – Hardware and Sound – Sound*.
- ▶ Mark *Realtek HDMI Output*.
- ▶ Select *Properties – Supported formats*.
- ▶ Deactivate the settings *DTS audio* and *Dolby digital*.
- ▶ Confirm the settings with *OK*.

Connecting USB devices

On the USB ports, you can connect external devices that also have a USB port (e.g. a DVD drive, a printer, a scanner or a modem).



USB devices are hot-pluggable. This means you can connect and disconnect devices while your operating system is running.

USB 2.0 has a data transfer rate of up to 480 Mbit/s.

Additional information can be found in the documentation for the USB devices.

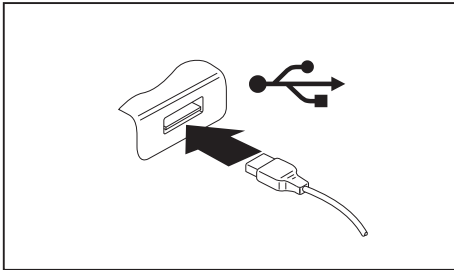

- ▶ Connect the data cable to the external device.
- ▶ Connect the data cable to the USB port on the Tablet PC.



Device drivers

USB devices will be automatically recognised and installed by your operating system.

How to remove USB devices correctly



Always correctly remove the device according to the rules described below, to ensure that none of your data is lost.

- ▶ Tap the symbol for safe removal of the hardware.
- ▶ Select the device which you want to shut down and remove.
- ▶ Tap *OK*.
- ↳ Wait for the dialogue box which tells you that it is now safe to remove the device.

Headphone port

Via the headphone port, you can connect either a headphone or an external speaker to your Tablet PC.

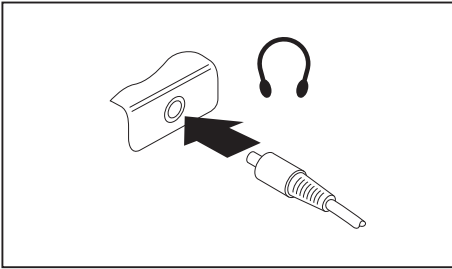

- ▶ Connect the audio cable to the external device.
- ▶ Connect the audio cable to the headphone port of the Tablet PC.
- ↳ The internal loudspeakers are disabled.



If you purchase a cable from a retailer, please note the following information:

The headphone port on your Tablet PC is a "3.5 mm jack socket".

If you want to connect headphones or a speaker you will need a "3.5 mm jack plug".

Settings in BIOS Setup Utility



To navigate more easily in the *BIOS Setup Utility*, you can use an external USB keyboard.

The *BIOS Setup Utility* allows you to set the system functions and the hardware configuration for the Tablet PC.

When it is delivered, the Tablet PC is set to factory default settings. You can change these settings in *BIOS Setup Utility*. Any changes you make take effect as soon as you save and exit the *BIOS Setup Utility*.

The *BIOS Setup Utility* program contains the following menus:

<i>About</i>	Displays information relating to the BIOS, processor and Tablet PC
<i>System</i>	Advanced system settings
<i>Advanced</i>	Configuration of various hardware components, such as mouse, keyboard, processor
<i>Security</i>	Password settings and security functions
<i>Boot</i>	Configuration of the start-up sequence
<i>Exit</i>	Exits the <i>BIOS Setup Utility</i>

Starting the BIOS Setup Utility

- ▶ Keep the "Change screen orientation" tablet button pressed and switch the Tablet PC on.
- ▶ If a password has been assigned, enter the password and press the Enter key.



If you have forgotten the password, contact your system administrator or contact our customer service centre.

The *BIOS Setup Utility* starts.

Operating BIOS Setup Utility

 i

Use the touchscreen to operate the function keys in the *BIOS Setup Utility*.

Tap on any element in the BIOS Setup menus or tap on the function or cursor keys indicated on the bottom of the screen.

 i

Press the **F1** key to display help on the operation of the *BIOS Setup Utility*. The description of the individual settings is shown in the right-hand window of the *BIOS Setup Utility*.

With the **F9** key you can load the default settings of the *BIOS Setup Utility*.

- ▶ Use the cursor keys **←** or **→** to select the menu you wish to access to make changes.
↳ The menu is displayed on the screen.
- ▶ Select the option you want to change with the cursor keys **↑** or **↓**.
- ▶ Press the Enter key.
- ▶ Press the **ESC** key to exit the selected menu.
- ▶ For future reference, make a note of the changes you have made (for example, in this manual).

Exiting BIOS Setup Utility

You need to select the desired option in the *Exit* menu and activate it by pressing the Enter key:

Exit Saving Changes - save changes and exit BIOS Setup Utility

- ▶ To save the current menu settings and exit the *BIOS Setup Utility*, select *Exit Saving Changes* and *Yes*.
- ↳ The Tablet PC is rebooted and the new settings come into effect.

Exit Discarding Changes – Discard changes and exit BIOS Setup Utility

- ▶ To discard the changes, select *Exit Discarding Changes* and *Yes*.
- ↳ The settings in place when *BIOS Setup Utility* was called remain effective. The *BIOS Setup Utility* is terminated and the Tablet PC is rebooted.

Load Setup Defaults – Copy Standard Entries

- ▶ To copy the standard entries for all menus of the *BIOS Setup Utility*, choose *Load Setup Defaults* and *Yes*.

Discard Changes – Discard changes without exiting the BIOS Setup Utility

- ▶ To discard the changes you have made, select *Discard Changes* and *Yes*.
- ↳ The settings in place when *BIOS Setup Utility* was called remain effective. You can now make additional settings in the *BIOS Setup Utility*.
- ▶ If you want to exit *BIOS Setup Utility* with these settings, select *Exit Saving Changes* and *Yes*.

Save Changes - save changes without exiting the BIOS Setup Utility

- ▶ To save the changes, select *Save Changes* and *Yes*.
- ↳ The changes are saved. You can now make additional settings in the BIOS Setup Utility.
- ▶ If you want to exit BIOS Setup Utility with these settings, choose *Exit Saving Changes* and *Yes*.

Save Changes and Power Off

- ▶ To save the changes and switch off your device, select *Save Changes and Power Off* and *Yes*.
- ↳ The changes are saved. Your device is shut down.

Troubleshooting and tips



Follow the safety notes in the "Safety/Regulations" manual when connecting or disconnecting cables.

If a fault occurs, try to correct it as described. If you fail to correct the problem, proceed as follows:

- ▶ Make a note of the steps and the circumstances that led to the fault. Also make a note of any error messages displayed.
- ▶ Switch the Tablet PC off.
- ▶ Please contact the Hotline/Service Desk.



You can find the telephone numbers in the service desk list. Please have the following information ready when you call:

- The model name and serial number of the Tablet PC. The serial number is located on a sticker on the underside of the Tablet PC.
- Notes of any messages that appear on the screen and information on acoustic signals.
- Any changes you have made to the hardware or software after receiving the Tablet PC.
- Any changes you have made to the *BIOS Setup* settings after receiving the Tablet PC.
- Your system configuration and all peripheral devices connected to your system.
- Your sales contract.



Our Tablet PCs have been designed primarily with mobile applications in mind. This means that considerable effort has been made to optimise components and equipment in terms of weight, space and energy requirements. Depending on the particular configuration you have purchased, it is possible that functionality may be slightly reduced compared to a desktop PC if you are running processor-intensive gaming software, e.g. games with intensive 3D graphics. Updating your hardware with drivers which have not been approved by Fujitsu Technology Solutions may result in performance losses, data losses or malfunction of the equipment. A list of approved drivers and current BIOS versions can be downloaded from: "<http://ts.fujitsu.com/support/downloads.html>"

Help if problems occur

Should you encounter a problem with your computer that you cannot resolve yourself:

- ▶ Note the ID number of your device. The ID number is found on the type rating plate on the back or underside of the casing.
- ▶ For further clarification of the problem, contact the Help Desk for your country (see the Help Desk list or visit the Internet at "<http://ts.fujitsu.com/support/service desk.html>"). When you do this, please have ready the ID number and serial number of your system.

The Tablet PC's date or time is incorrect

Cause	Troubleshooting
Time and date are incorrect.	▶ With the <i>BIOS-Setup-Utility</i> , you can set the date and time in the <i>main</i> menu.
Date and time are still set incorrectly after switching on the Tablet PC.	▶ Please contact your sales outlet or our Hotline/Service Desk.

Battery indicator does not illuminate

Cause	Fault elimination
The battery is not installed correctly.	<ul style="list-style-type: none"> ▶ Switch the Tablet PC off. ▶ Check whether the battery is installed correctly in its compartment. ▶ Switch the Tablet PC on.
The battery is fully discharged.	<ul style="list-style-type: none"> ▶ Charge the battery. <p>or</p> <ul style="list-style-type: none"> ▶ Install a charged battery. <p>or</p> <ul style="list-style-type: none"> ▶ Connect the Tablet PC to a mains outlet using the mains adapter.

The Tablet PC's touchscreen remains dark

Cause	Troubleshooting
Touchscreen is switched off.	▶ Press a key (external keyboard) or tap on the touchscreen.
External monitor or television set connected.	▶ Check whether the graphics driver settings are correct or whether an external monitor has been detected in "Intel Graphics Media Accelerator Driver for mobile".

The display on the Tablet PC's touchscreen is difficult to read.

Cause	Troubleshooting
Reflected glare	<ul style="list-style-type: none"> ▶ Move the Tablet PC into a different position. ▶ Increase the brightness of the screen.

The external monitor remains blank

Cause	Troubleshooting
Monitor is switched off.	▶ Switch the external monitor on.
Power saving has been activated (monitor is blank).	▶ Press a key (external keyboard) or tap on the touchscreen.
Brightness is set to dark.	▶ Adjust the brightness of the monitor.
Screen output is set on the Tablet PC's touchscreen.	▶ Check whether the graphics driver settings are correct or whether an external monitor has been detected in "Intel Graphics Media Accelerator Driver for mobile".
The external monitor's power cable or data cable is not connected properly.	<ul style="list-style-type: none"> ▶ Switch off the Tablet PC and the external monitor. ▶ Check whether the power cable is plugged properly into the external monitor and into the power socket. ▶ Check whether the data cable is properly connected to the Tablet PC and the external monitor (if it is plugged in with a connector). ▶ Switch on the Tablet PC and the external monitor.

The external monitor is blank or the image is unstable

Cause	Troubleshooting
The wrong external monitor has been selected or the wrong screen resolution has been set for the application program.	<ul style="list-style-type: none"> ▶ Terminate the application program in Windows. If the error persists after terminating the program, use the key combination for switching the screen output in order to switch to the touchscreen of the Tablet PC. Change the following setting: ▶ Set the screen resolution: Set the screen resolution as described in the documentation for your operating system. ▶ Select monitor: Select monitor 1 or 2 as described in the documentation for your operating system.

The cursor does not correctly follow the pen movements

Cause	Fault elimination
Pen incorrectly calibrated	<ul style="list-style-type: none"> ▶ Calibrate the pen as shown under <i>Hardware and Sound / Tablet PC Settings</i> in the Control Panel, see "Setting the pen", Page 34 and "Calibrating the pen", Page 35.

Pen input not working

Cause	Troubleshooting
Incorrect driver installed.	<ul style="list-style-type: none"> ▶ If your device is one which can only be operated using the pen, install the driver for the standard model. or ▶ If your device is one which can be operated using the pen and by finger, install the driver for the "Dual Digitizer" model.

The Tablet PC does not start after switch on

Cause	Troubleshooting
The battery is not installed correctly.	<ul style="list-style-type: none"> ▶ Check whether the battery is installed correctly in its compartment. ▶ Switch on the Tablet PC.
The battery is dead.	<ul style="list-style-type: none"> ▶ Charge the battery. or ▶ Insert a charged battery. or ▶ Connect the mains adapter to the Tablet PC.
The power adapter is not connected correctly.	<ul style="list-style-type: none"> ▶ Check whether the mains adapter is connected correctly to the Tablet PC. ▶ Switch on the Tablet PC.

The Tablet PC stops working

Cause	Troubleshooting
The Tablet PC is in energy saving mode.	▶ Leave energy saving mode.
An application programme has caused the malfunction.	▶ Close the application program or restart the Tablet PC (by restarting the operating system or switching the device off and back on again).
The battery is dead.	▶ Charge the battery. or ▶ Insert a charged battery. or ▶ Connect the mains adapter to the Tablet PC.

The printer does not print

Cause	Troubleshooting
The printer is not switched on.	▶ Make sure that the printer is switched on and ready for operation (refer to the documentation supplied with the printer).
The printer is not connected correctly.	▶ Check that the data cable connecting the Table PC to the printer is properly connected.
The printer driver is faulty or not correctly installed, or it is the wrong printer driver.	▶ Check that the data cable connecting the Tablet PC to the printer is properly connected. ▶ Check whether the correct printer driver is loaded (refer to the printer documentation).

The radio connection to a network does not work

Cause	Troubleshooting
The wireless component is disabled.	▶ Switch the radio component on (see "Switching the wireless components on and off", Page 47).
The wireless component is enabled. Despite this, the wireless connection to a network does not work.	▶ Check whether the radio connection is switched on via the software. ▶ Further information on using the radio component can be found in the help files.

The battery discharges too quickly

Cause	Troubleshooting
The battery is either too hot or too cold. In this case the battery indicator flashes.	<ul style="list-style-type: none"> ▶ Bring the Tablet PC up/down to a normal temperature again. ▶ If the operating time of the battery life is extremely short, the battery is probably too old. Replace battery if necessary.
You may have an application running that consumes a great deal of power due to frequent accessing of the hard disk or optical drive.	<ul style="list-style-type: none"> ▶ Use the mains adapter as frequently as possible.
The maximum brightness may have been set for the screen.	<ul style="list-style-type: none"> ▶ Reduce the brightness of the screen to lower energy consumption: You will find the setting under <i>Control Panel – Hardware and Sounds – Windows Mobility Center</i>.

SmartCard reader is not recognised.

Cause	Troubleshooting
Chip card inserted incorrectly.	<ul style="list-style-type: none"> ▶ Make sure you have inserted your SmartCard into the SmartCard reader with the chip facing upwards. ▶ Check whether the SmartCard you are using is supported. Your SmartCard must comply with the ISO standard 7816-1, -2, -3 and -4.

SmartCard PIN forgotten

Cause	Troubleshooting
PIN forgotten	<ul style="list-style-type: none"> ▶ If you work in a network, contact your system administrator, who can unlock your Tablet PC with a supervisor PIN.

SmartCard lost

Cause	Troubleshooting
SmartCard lost	<ul style="list-style-type: none"> ▶ If you work in a network, contact your system administrator, who can boot your Tablet PC with a Supervisor SmartCard.

User and/or supervisor SmartCard lost

Cause	Troubleshooting
User and/or supervisor SmartCard lost	<ul style="list-style-type: none"> ▶ If you have lost your User SmartCard, you can continue working with the Supervisor SmartCard and initialise a new User SmartCard or deactivate the SystemLock function. ▶ If you have lost the Supervisor SmartCard, you can continue working, but you no longer have all your rights and can no longer initialise a Supervisor SmartCard. ▶ If you have lost both SmartCards, you can no longer boot your system. Please contact our Service Desk. You must provide proof of ownership for the device. Then the Service Desk will refer you to our service partner, who will unlock your device (for a charge).

Acoustic warnings

Cause	Troubleshooting
<p>A beep sounds every few seconds.</p> <p>The battery is almost flat.</p>	<ul style="list-style-type: none"> ▶ Charge the battery.

Error messages on the screen

This section describes the error messages generated by the BIOS Setup. Error messages displayed by the operating system or programmes are described in the relevant documentation.



If the error message appears repeatedly, despite troubleshooting measures, please contact the place of purchase or our customer service centre.

Error message/cause	Resolution
<p><i>CMOS battery bad</i></p> <p>If the error message occurs repeatedly, the buffer battery in the Tablet PC is flat.</p>	<ul style="list-style-type: none"> ▶ Contact your sales outlet or our customer service centre.
<p><i>System CMOS checksum bad - default configuration used</i></p> <p>The system configuration information is incorrect.</p>	<ul style="list-style-type: none"> ▶ Switch off the Tablet PC. ▶ Switch on the Tablet PC. ▶ Keep the "Change screen orientation" tablet button pressed and switch on the Tablet PC. ▶ In the <i>BIOS Setup</i>, select the <i>Exit</i> menu. ▶ Select the entry <i>Load Setup Defaults</i>. ▶ Select <i>OK</i> and press the Enter key.
<p><i>Extended memory failed at offset: xxxx Failing Bits: zzzz zzzz</i></p> <p>When testing the extended memory an error has resulted at the address xxxx.</p>	<ul style="list-style-type: none"> ▶ Contact your sales outlet or our customer service centre.
<p><i>Failure Fixed Disk n</i></p> <p>The settings of the hard disk drive are incorrect.</p>	<ul style="list-style-type: none"> ▶ Start the <i>BIOS Setup (Primary Master submenu)</i> and select the correct settings.
<p><i>Keyboard controller error</i></p>	<ul style="list-style-type: none"> ▶ Switch off your Tablet PC with the ON/OFF switch. ▶ Wait 3 - 5 seconds and switch on the Tablet PC again.
<p><i>Keyboard error</i></p>	<p>If you are using an external keyboard:</p> <ul style="list-style-type: none"> ▶ Check the connection and reboot the Tablet PC.
<p><i>nn Stuck key</i></p>	<ul style="list-style-type: none"> ▶ Make sure that no key is pressed.
<p><i>Operating system not found</i></p>	<ul style="list-style-type: none"> ▶ Check in the <i>BIOS Setup</i> whether your hard disk has been set correctly. ▶ Make sure that the operating system is installed on the corresponding drive.
<p><i>Press <F1> to resume, <F2> to SETUP</i></p> <p>This error message appears if an error occurs during the self-test before starting the operating system.</p>	<ul style="list-style-type: none"> ▶ Press the "Alt" key on the Tablet PC to boot the operating system ▶ Keep the "Change screen orientation" tablet button pressed and switch on the Tablet PC to access the <i>BIOS setup</i>.
<p><i>Real time clock error</i></p>	<ul style="list-style-type: none"> ▶ Contact your sales outlet or our customer service centre.
<p><i>nnnnK Shadow RAM failed at offset: xxxx Failing Bits: zzzz</i></p>	<ul style="list-style-type: none"> ▶ Contact your sales outlet or our customer service centre.
<p><i>System battery is dead - Replace and run SETUP</i></p>	<ul style="list-style-type: none"> ▶ Contact your sales outlet or our customer service centre.
<p><i>System cache error - Cache disabled</i></p>	<ul style="list-style-type: none"> ▶ Contact your sales outlet or our customer service centre.
<p><i>System timer error</i></p>	<ul style="list-style-type: none"> ▶ Contact your sales outlet or our customer service centre.

Technical data

Tablet PC

General	
Processor	Intel Atom Z670
Main memory (SO DIMM)	2 GByte DDR2 onboard
Electrical data	
Safety regulations complied with	CE
Protection class	II
Maximum power consumption: (Tablet PC on with battery charging)	40 W
Touchscreen	
Size	25.65 cm 16:10 TFT WXGA
Resolution	1280 x 800 pixels/16 million colours
Pixel class	II
Brightness control	6 levels
Technology	Wide-View High-Bright WXGA Display with LED Background Lighting
Digitizer and glass panel	Dual digitizer with matt touch screen
Cameras	<ul style="list-style-type: none"> • Front: VGA camera • Back: 1.3 megapixels
Graphics card	
Chip	Intel GMA 600
Maximum resolution on external display:	1280 x 720 pixels
Dimensions	
Width x depth x height	275 mm x 192 mm x 16.2 mm
Weight depending on configuration	<ul style="list-style-type: none"> • from 0.76 kg with a 2-cell battery • from 0.87 kg with a 4-cell battery
Input devices	
Tablet buttons	3 keys
Pen	1 freely programmable rocker button / eraser
Slots	
Memory card slot	1 x SD or MS card
SmartCard slot	1 x
SIM card slot	1 x
Ports	
HDMI port	1 x
Headphones port/Line Out	3.5 mm stereo mini jack
Docking port	1 x
USB (Universal Serial Bus)	1 x USB 2.0

Technical data

Ambient conditions	
Environment class DIN IEC 721	7K1
Mechanism class DIN IEC 721	7M2
Operating temperature	5°C 35°C
Transport temperature (2K2)	-15°C 60°C

Rechargeable battery



You can find information on the batteries used in your device at ["http://ts.fujitsu.com/support"](http://ts.fujitsu.com/support).

	4-cell lithium polymer battery 5240 mAh	2-cell lithium polymer battery 2620 mAh
Rated voltage	7.2 V	7.2 V
Rated capacity	38 Wh	19 Wh

Mains adapter (40 W)

Rated voltage	19 V
Max. rated current	2.1 A

An additional mains adapter or power cable can be ordered at any time.

Cradle (optional)

Electrical data	
Safety regulations complied with	CE
Protection class	II
Ports	
USB (Universal Serial Bus)	4 x USB 2.0
Docking port	30-pin
Ambient conditions	
Environment class DIN IEC 721	7K1
Mechanism class DIN IEC 721	7M2
Operating temperature	5 °C 35°C
Transport temperature	-15 °C 60 °C

Manufacturer's notes

Disposal and recycling

Information about this subject can be found on your Tablet PC or on our Internet pages.

Declarations of Conformity

The "Declarations of Conformity" for the device can be found at our Internet address under: ["http://ts.fujitsu.com/ce"](http://ts.fujitsu.com/ce).

Fujitsu Technology Solutions hereby declares that your device is in compliance with the essential requirements and other relevant provisions of Directive 1999/5/EC.

Tested safety (TS, depending on the device)



With the AntiGlare display, the device meets the requirements of the following directives:

- EN60950-1:2001
- DIN EN ISO 13406-2:2003
- EK1-ITB 2000:2008
- DIN EN ISO 9241-4:1999

CE marking



CE marking for devices with radio component

This equipment complies with the requirements of Directive 1999/5/EC of the European Parliament and Commission from 9 March, 1999 governing Radio and Telecommunications Equipment and mutual recognition of conformity.

This equipment can be used in the following countries:

Belgium	Bulgaria	Denmark	Germany
Estonia	Finland	France	Greece
UK	Ireland	Iceland	Italy
Latvia	Liechtenstein	Lithuania	Luxembourg
Malta	The Netherlands	Norway	Austria
Poland	Portugal	Rumania	Sweden
Switzerland	Slovakia	Slovenia	Spain
Czech Republic	Hungary	Cyprus	

Contact the corresponding government office in the respective country for current information on possible operating restrictions. If your country is not included in the list, then please contact the corresponding supervisory authority as to whether the use of this product is permitted in your country.

Regulatory notices



If there is no FCC logo and also no FCC ID on the device then this device is not approved by the Federal Communications Commission (FCC) of the USA. Although it is not explicitly forbidden to travel in the US trading area carrying this device, to avoid trouble at customs clearance, Fujitsu Technology Solutions GmbH recommends not to bring this device into the US trading area.

Regulatory information for Tablet PCs without radio device

NOTICE:

Changes or modifications not expressly approved by Fujitsu Technology Solutions could void this user's authority to operate the equipment.

Notice to Users of Radios and Television

These limits are designed to provide reasonable protection against harmful interference in a residential installation. This equipment generates, uses, and can radiate radio frequency energy and, if not installed and used in accordance with the instructions, may cause harmful interference to radio communications. However, there is no guarantee that interference will not occur in a particular installation. If this equipment does cause harmful interference to radio or television reception, which can be determined by turning the equipment off and on, the user is encouraged to try to correct the interference by one or more of the following measures:

- Reorient or relocate the receiving antenna.
- Increase the separation between the equipment and receiver.

- Connect the equipment into an outlet that is on a different circuit than the receiver.
- Consult the dealer or an experienced radio/TV technician for help.

Notice to Users of the US Telephone Network

Your Tablet PC may be supplied with an internal modem which complies with Part 68 of the FCC rules. On this Tablet PC is a label that contains the FCC Registration Number and the Ringer Equivalence Number (REN) for this equipment among other information. If requested, the user must provide their telephone company with the following information:

1. The telephone number to which the Tablet PC is connected.
2. The Ringer Equivalence Number (REN) for this equipment.
3. The equipment requires a standard modular jack type USOC RJ-11C which is FCC Part 68 compliant.
4. The FCC Registration Number.

This equipment is designed to be connected to the telephone network or premises wiring using a standard modular jack type USOC RJ-11C which is FCC Part 68 compliant and a line cord between the modem and the telephone network with a minimum of 26AWG.

The REN is used to determine the number of devices that you may connect to your telephone line and still have all of those devices ring when your number is called. Too many devices on one line may result in failure to ring in response to an incoming call. In most, but not all, areas the sum of the RENs of all of the devices should not exceed five (5). To be certain of the number of devices you may connect to your line, as determined by the RENs, contact your local telephone company. If this equipment causes harm to the telephone network, your telephone company may discontinue your service temporarily. If possible, they will notify you in advance. If advance notice is not practical they will notify you as soon as possible. You will also be advised of your right to file a complaint with the FCC.

This fax modem also complies with fax branding requirements per FCC Part 68.

Your telephone company will probably ask you to disconnect this equipment from the telephone network until the problem is corrected and you are sure that the equipment is not malfunctioning. This equipment may not be used on coin-operated telephones provided by your telephone company. Connection to party lines is subject to state tariffs. Contact your state's public utility commission, public service commission or corporation commission for more information.

This equipment includes automatic dialing capability. When programming and/or making test calls to emergency numbers:

- Remain on the line and briefly explain to the dispatcher the reason for the call.
- Perform such activities in off-peak hours, such as early morning or late evening.

FCC rules prohibit the use of non-hearing aid compatible telephones in the following locations or applications:

- All public or semi-public coin-operated or credit card telephones.
- Elevators, highways, tunnels (automobile, subway, railroad or pedestrian) where a person with impaired hearing might be isolated in an emergency.
- Places where telephones are specifically installed to alert emergency authorities such as fire, police or medical assistance personnel.
- Hospital rooms, residential health care facilities, convalescent homes and prisons.
- Hotel, motel or apartment lobbies.
- Stores where telephones are used by patrons to order merchandise.

- Public transportation terminals where telephones are used to call taxis or to reserve lodging or rental cars.
- In hotel and motel rooms as at least ten percent of the rooms must contain hearing aid-compatible telephones or jacks for plug-in hearing aid compatible telephones which will be provided to hearing impaired customers on request.

DOC (Industry CANADA) notices

Notice to Users of Radios and Television

This Class B digital apparatus meets all requirements of Canadian Interference-Causing Equipment Regulations.

CET appareil numérique de la class B respecte toutes les exigence du Règlement sur le matériel brouilleur du Canada.

Notice to Users of the Canadian Telephone Network

NOTICE:

This equipment meets the applicable Industry Canada Terminal Equipment Technical Specifications. This is confirmed by the registration number. The abbreviation, IC, before the registration number signifies that registration was performed based on a Declaration of Conformity indicating that Industry Canada technical specifications were met. It does not imply that Industry Canada approved the equipment. Before connecting this equipment to a telephone line the user should ensure that it is permissible to connect this equipment to the local telecommunication facilities. The user should be aware that compliance with the certification standards does not prevent service degradation in some situations.

Repairs to telecommunication equipment should be made by a Canadian authorised maintenance facility. Any repairs or alterations not expressly approved by Fujitsu or any equipment failures may give the telecommunication company cause to request the user to disconnect the equipment from the telephone line.

NOTICE:

The Ringer Equivalence Number (REN) for this terminal equipment is 0.0. The REN assigned to each terminal equipment provides an indication of the maximum number of terminals allowed to be connected to a telephone interface. The termination on an interface may consist of any combination of devices subject only to the requirement that the sum of the Ringer Equivalence Numbers of all the devices does not exceed five.



CAUTION:

For safety, users should ensure that the electrical ground of the power utility, the telephone lines and the metallic water pipes are connected together. Users should NOT attempt to make such connections themselves but should contact the appropriate electric inspection authority or electrician. This may be particularly important in rural areas.

Avis Aux Utilisateurs Du Réseau Téléphonique Canadien

AVIS : Le présent matériel est conforme aux spécifications techniques d'Industrie Canada applicables au matériel terminal. Cette conformité est confirmée par le numéro d'enregistrement. Le sigle IC, placé devant le numéro d'enregistrement, signifie que l'enregistrement s'est effectué conformément à une déclaration de conformité et indique que les spécifications techniques d'Industrie Canada ont été respectées. Il n'implique pas qu'Industrie Canada a approuvé le matériel.

Avant de connecter cet équipement à une ligne téléphonique, l'utilisateur doit vérifier s'il est permis de connecter cet équipement aux installations de télécommunications locales. L'utilisateur est averti que même la conformité aux normes de certification ne peut dans certains cas empêcher la dégradation du service.

Les réparations de l'équipement de télécommunications doivent être effectuées par un service de maintenance agréé au Canada. Toute réparation ou modification, qui n'est pas expressément approuvée par Fujitsu, ou toute défaillance de l'équipement peut entraîner la compagnie de télécommunications à exiger que l'utilisateur déconnecte l'équipement de la ligne téléphonique.

AVIS : L'indice d'équivalence de la sonnerie (IES) du présent matériel est de 0.0. L'IES assigné à chaque dispositif terminal indique le nombre maximal de terminaux qui peuvent être raccordés à une interface téléphonique. La terminaison d'une interface peut consister en une combinaison quelconque de dispositifs, à la seule condition que la somme d'indices d'équivalence de la sonnerie de tous les dispositifs n'excède pas 5.



AVERTISSEMENT:

Pour assurer la sécurité, les utilisateurs doivent vérifier que la prise de terre du service d'électricité, les lignes téléphoniques et les conduites d'eau métalliques sont connectées ensemble. Les utilisateurs NE doivent PAS tenter d'établir ces connexions eux-mêmes, mais doivent contacter les services d'inspection d'installations électriques appropriés ou un électricien. Ceci peut être particulièrement important en régions rurales.

UL Notice

This unit requires an AC adapter to operate. Only use a UL Listed Class 2 adapter. The correct output rating is indicated on the AC adapter label. Refer to the illustration below for the correct AC Adapter output polarity:



CAUTION:

To reduce the risk of fire, use only 26AWG or larger telecommunications line cord.

For Authorized Repair Technicians Only



CAUTION:

For continued protection against risk of fire, replace only with the same type and rating fuse.



WARNING:

Danger of explosion if Lithium (CMOS) battery is incorrectly replaced. Replace only with the same or equivalent type recommended by the manufacturer.

Dispose of used batteries according to the manufacturer's instructions.

FCC Regulatory information for Tablet PCs with radio device

Federal Communications Commission statement

This device complies with Part 15 of FCC Rules. Operation is subject to the following two conditions: (1) this device may not cause interference, and

(2) this device must accept any interference, including interference that may cause undesired operation of this device.

FCC Interference Statement

This equipment has been tested and found to comply with the limits for a Class B digital device, pursuant to Part 15 of the FCC Rules. These limits are designed to provide reasonable protection against harmful interference in a residential installation. This equipment generates, uses, and can radiate radio frequency energy. If not installed and used in accordance with the instructions, it may cause harmful interference to radio communications.

However, there is no guarantee that interference will not occur in a particular installation.

If this equipment does cause harmful interference to radio or television reception, which can be determined by turning the equipment off and on, the user is encouraged to try to correct the interference by one or more of the following measures:

1. Reorient or relocate the receiving antenna.
2. Increase the distance between the equipment and the receiver.
3. Connect the equipment to an outlet on a circuit different from the one the receiver is connected to.
4. Consult the dealer or an experienced radio/TV technician for help.

Please note the following regulatory information related to the optional radio device.

FCC Radio Frequency Exposure statement

This radio device has been evaluated under FCC Bulletin OET 65C and found compliant with the requirements as set forth in CFR 47 Sections 2.1091, 2.1093, and 15.247 (b) (4) addressing RF Exposure from radio frequency devices. The radiated output power of this radio device is far below the FCC radio frequency exposure limits. Nevertheless, this device shall be used in such a manner that the potential for human contact during normal operation is minimized. When using this device, a certain separation distance between antenna and nearby persons must be maintained to ensure RF exposure compliance. In order to comply with RF exposure limits established in the ANSI C95.1 standards, the distance between the antennas and the user should not be less than 20 cm (8 inches).

Regulatory Notes and Statements

Radio device, health and authorisation for use

Radio-frequency electromagnetic energy is emitted from the wireless devices. The energy levels of these emissions, however, are far much less than the electromagnetic energy emissions from wireless devices such as mobile phones. Radio devices are safe for use by consumers because they operate within the guidelines found in radio frequency safety standards and recommendations.

The use of the radio devices may be restricted in some situations or environments, such as:

- on board an airplane, or
- in an explosive environment, or
- in situations where the interference risk to other devices or services is perceived or identified as harmful.

In cases in which the policy regarding use of radio devices in specific environments is not clear (e.g., airports, hospitals, chemical/oil/gas industrial plants, private buildings), obtain authorization to use these devices prior to operating the equipment.

Regulatory Information/Disclaimers

Installation and use of this radio device must be in strict accordance with the instructions included in the user documentation provided with the product. Any changes or modifications made to this device that are not expressly approved by the manufacturer may void the user's authority to operate the equipment. The manufacturer is not responsible for any radio or television interference caused by unauthorized modification of this device, or the substitution or attachment of connecting cables and equipment other than those specified by the manufacturer. It is the responsibility of the user to correct any interference caused by such unauthorized modification, substitution or attachment. The manufacturer and its authorized resellers or distributors will assume no liability for any damage or violation of government regulations arising from failure to comply with these guidelines.

Export restrictions

This product or software contains encryption code which may not be exported or transferred from the US or Canada without an approved US Department of Commerce export license. This device complies with Part 15 of FCC Rules, as well as ICES 003 B / NMB 003 B. Operation is subject to the following two conditions:

- (1) this device may not cause harmful interference, and
- (2) this device must accept any interference received, including interference that may cause undesirable operation.

Modifications not expressly authorised by Fujitsu Technology Solutions may invalidate the user's right to operate this equipment.

Index

- A**
 - Acoustic error messages 73
 - Audio ports 63
- B**
 - Battery
 - battery life 39
 - caring for and maintaining 40
 - charge level 40, 43
 - charging 40
 - self-discharge 40
 - storage 40
 - Battery status meter 40
 - Battery:
 - discharges too quickly 72
 - BIOS Setup Utility
 - calling 64
 - exiting 66
 - operating 65
 - protecting with password 54
 - settings 64
 - Bluetooth
 - Switching off module 47
 - Switching on module 47
 - Bluetooth, safety notes 11
 - Buffer battery, load 68
- C**
 - CE marking 78
 - Charging capacity, battery 40
 - Cleaning 16
 - Configuration, BIOS Setup Utility 64
 - Connecting audio devices 63
 - Connecting headphones 63
 - Cradle
 - Connecting a Tablet PC 50
 - Ports 49
 - Crystal View display
 - cleaning 16
- D**
 - Date is incorrect 68
 - Declaration of conformity 77
 - Device
 - setting up 18
 - Devices
 - connecting 60
 - disconnecting 60
 - Display orientation
 - selecting 23
 - DOC (INDUSTRY CANADA) NOTICES 80
- E**
 - Energy
 - energy saving 15
 - Energy saving 15
 - Energy saving mode
 - leaving 71
 - Error message:
 - on the screen 73
 - Error messages on the screen 73
 - Errors
 - Acoustic warnings 73
- F**
 - Fault
 - correction 67
 - Fingerprint sensor 53
 - configure 53
 - First-time setup 17
- G**
 - Getting started 17
 - GPS 48
- H**
 - Hardware configuration 64
 - HDMI port 61
- I**
 - Important notes 11
 - Incorrect date/time 68
- K**
 - Keyboard
 - cleaning 16
- L**
 - Landscape orientation
 - screen 23
 - Life, battery 39
- M**
 - Mains adapter
 - connecting 18
 - setting up 18

- Memory card
 - handling 44
 - inserting 44
 - removing 45
- Mobile operation 15
- Monitor
 - drifting display 69
 - remains blank 69
- N**
- Notes 11
 - cleaning 16
 - disposal / recycling 77
 - energy saving 15
 - Safety 11
 - touchscreen 22
 - transport 15
- O**
- Operating system
 - activating system protection 56
 - cancel system protection 56
 - protecting with password 55
- P**
- Packaging 17
- Password
 - changing 55
 - entering 55
 - removing 55
- Password protection 54
- Password protection:
 - hard disk 56
- Peripheral devices
 - connecting 60
 - disconnecting 60
- Portrait orientation
 - screen 23
- Ports
 - Cradle 49
- Power
 - power consumption 43
 - power-management features 43
- Power-on indicator 21
- Preparing for operation 18
- Printer does not print 71
- R**
- Radio component:
 - safety notes 11
- Rechargeable battery 39
 - see Battery 39
- Regulatory information
 - Tablet PCs with radio device 81
 - Tablet PCs without radio device 78
- S**
- Safety notes 11
- Screen
 - no screen display 69
- Security functions 53
 - SystemLock 58
- Security functions,
 - SmartCard 58
- Selecting a location 18
- Self-discharge, battery 40
- Setup
 - see BIOS Setup Utility 64
- Slot
 - Memory cards 44
- Status indicators 20
- Summer time 68
- Supervisor password
 - changing 55
 - entering 55
 - removing 55
- Suspend/Resume button 21
- Switching on for the first time 19
- Symbols
 - indicators 20
- System configuration 64
- System settings, BIOS Setup Utility 64
- T**
- Tablet PC
 - before you travel 15
 - cleaning 16
 - switching off 21
 - transporting 15–16
 - using 20
- Tablet PC, operation 20
- Tablet PC: switching on 21
- Technical data
 - Mains adapter 76
- The radio connection to a network does
 - not work 71
- The Tablet PC
 - cannot be started 70
 - doesn't work. 71
- Time not correct 68
- Time, daylight savings 68
- Tips 67

- Touchpad
 - cleaning 16
- Touchscreen
 - cleaning 16
 - difficult to read 68
 - notes 22
 - reflected glare 68
 - remains blank 68
- touchscreen is too dark 68
- TPM 59
- Transport
 - Transport damage 17
- Transportation 15–16
- Travel, Tablet PC 15
- Troubleshooting 67
- Trusted Platform Module 59

U

- USB ports 62
- User password
 - changing 55
 - entering 55
 - removing 55

W

- Webcam 39
- Wireless LAN
 - Switching off module 47
 - Switching on module 47
- Wireless LAN:
 - safety notes 11